



Series 942

User's Manual



TOTAL
CUSTOMER
SATISFACTION

**1/4 DIN
Microprocessor-Based
Ramping Control**



Watlow Controls

1241 Bundy Blvd., P.O. Box 5580, Winona, MN 55987-5580, Phone: 507/454-5300, Fax: 507/452-4507

W942-XUMN Rev. R00
June, 1995
Supersedes:
W942-MA40-9305

\$10.00
Made in the U.S.A.

 Printed on Recycled Paper



Page	Item
	Chapter 1
4	Starting Out With The Watlow Series 942-
4	General Description
5	Opening the 942
5	Set the DIP Switches
	Chapter 2
6	How To Install And Wire The Series 942-
6	System Planning
6	Installation Information
7	Dimensional Information
8	Wiring The Series 942
8	Sensor Installation Guidelines
9	Input Wiring
11	Output 1 Wiring
15	Output 2 Wiring
17	Auxiliary Wiring
20	System Wiring Example
	Chapter 3
21	How To Use the Keys And Displays
	Chapter 4
22	How To Setup The Series 942
22	Entering The Setup Menu
23	Setup Parameters
28	Operation Menu and Parameters
	Chapter 5
31	Programming the Seres 942
31	Program Menu
32	Program Parameters
34	Running the Series 942
35	Resume a Profile
36	Event Outputs
37	Multiple Profiles
37	Jumploops
38	Programming a Ramping Profile
38	Running Your Profile
39	Editing Your Profile
	Chapter 6
	How To Tune and Operate
40	Tuning - Automatic and Manual
42	Changing the Auxiliary Jumper Position
42	Using Alarms
44	Error Code Messages & Actions
	Appendix 1
46	Specification
48	Model Number Information
	Appendix 2
49	Installation Guidelines For Preventing Noise
51	Eliminating Noise
52	Checking For Ground Loops
52	Noise Suppression Devices Available...
53	Line Filtering Configurations For Controls
	Appendix 3
54	Entering the Calibration Menu
56	Calibration Procedures
64	Glossary
66	Index
67	Warranty>Returns

Figures, Tables, Charts

Page	Item	Figure
4	Series 942 Input & Output Overview	1
5	How to Open the Series 942	2
5	DIP Switch Location and Orientation	3
6	Overview of the Series 942	4
8	Series 942 Faceplate Dimensions	5
8	Series 942 Panel Cutout Dimensions	6
8	Series 942 Sideview Dimensions	7
9	120 VAC Power Wiring	8
9	240 VAC Power Wiring	9
10	Thermocouple Wiring Diagram	10
10	RTD Wiring Diagram	11
11	0 - 5 Process Input Wiring Diagram	12
11	4 - 20 Process Input Wiring Diagram	13
12	Solid State Relay, Output 1 Wiring	14
12	DC (Open Collector) Output 1 Wiring	15
13	6 Amp Mechanical Relay, Output 1 Wiring	16
13	4 - 20mA Process, Output 1 Wiring	17
14	0 - 5VDC Process, Output 1 Wiring	18
14	S.S. Relay, w/o contact supp., Output 1	19
15	S.S. Relay, Output 2 Wiring Diagram	20
15	DC (open Collector), Output 2 Wiring	21
16	6A Mechanical Relay, Output 2 Wiring	22
16	S.S. Relay, w/o contact supp., Output 2	23
17	Auxiliary Option 1, 1 - 6 Amp Relay	24
17	Auxiliary Option 2, 2 - 6 Amp Relays	25
18	Auxiliary Option 3, 6 Amp Relay/0-5ret.	26
18	Auxiliary Option 4, 6 Amp Relay/4-20ret.	27
19	Auxiliary Option 5, None/0-5Retransmit	28
19	Auxiliary Option 6, None/4-20mA Retransmit	29
20	System Wiring Example	30
21	Series 942 Keys and Displays	31
22	Entering the Setup Menu	32
22	The Setup Menu	33
28	The Operation Menu	34
31	The Program Menu	35
34	The Run Menu	36
37	Guaranteed Soak Deviation Example	37
42	Auxiliary Jumper Location	38
43	Deviation Alarm Example	39
43	Alarm Display Examples	40
44	Error Code Display Example	41
53	Differential Mode Filter Wiring	42
53	Common Mode Filter Wiring	43
53	Combination Filter Wiring	44
54	The Calibration Menu	45
55	Calibration Parameters	46
		Tables
26	Input Ranges	1
27	Setup MenuParameters/Description	2
30	Operation Menu Parameters/Description	3
38	Series 942 Ramp and Soak Profile	4
39	Editing Your Profile, steps 4 - 7	5
52	Noise Suppression Device Ratings	6
57	RTD Settings	7
		Charts
35	Master Step Chart	1

Chapter 1

The Watlow Series 942, A Microprocessor-Based Control

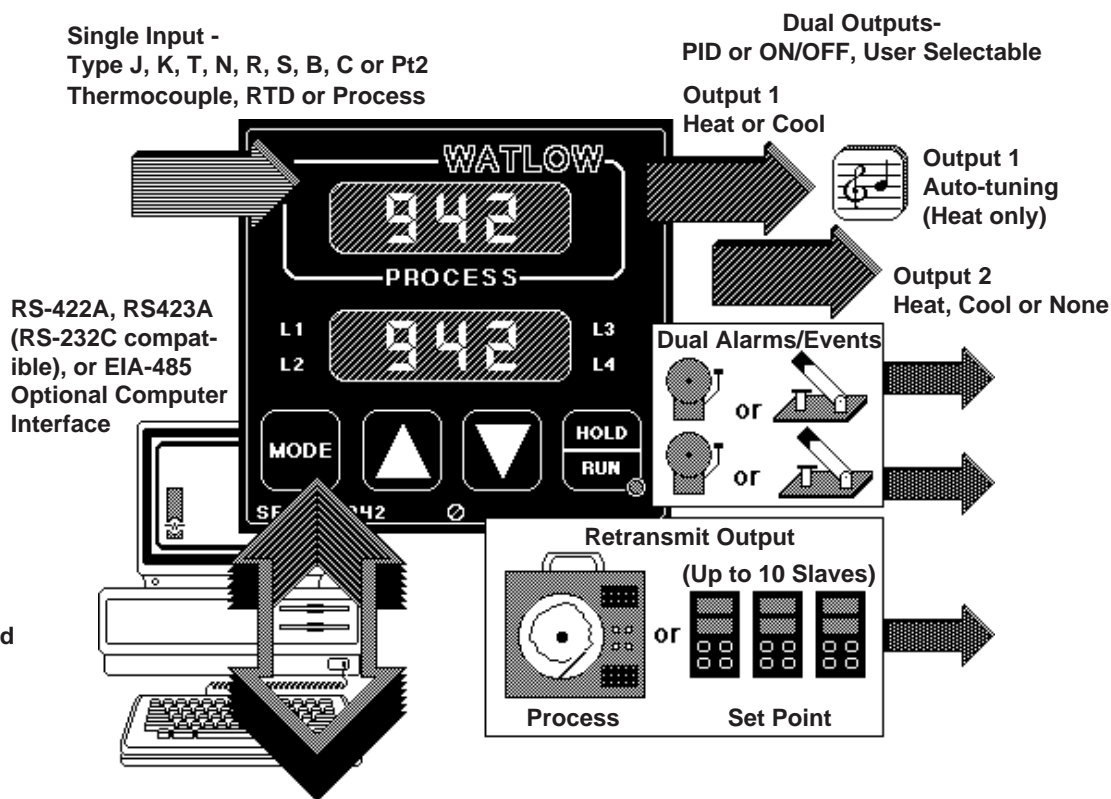

Figure 1 - Series 942 Input and Output Overview.

General Description

Welcome to the Watlow Series 942, a 1/4 DIN microprocessor-based ramping temperature control. It is a single input, dual output, auto-tuning control with 24 step program capability and easy fixed set point operation. The 942 accepts a Type J, K, T, N, R, S, B, C or Platine 2 thermocouple, RTD, or process input. The primary output is heating or cooling, while the secondary output can be heating, cooling or none.

With the Series 942 you can select either PID or ON/OFF for Output 1 or 2. You can input a complete set of PID parameters for both outputs, including proportional band, reset/integral and rate/derivative. You can also select automatic tuning for Output 1 while in the heating mode. By setting either output's proportional band to zero, the Series 942 becomes a simple ON/OFF control with the switching differential selectable under the HYS Setup parameter.

Two optional auxiliary outputs may be alarms or events. An event is an ON/OFF mechanical relay output. Events are based on time, and can trigger peripheral equipment or processes. An optional retransmit output is offered in lieu of one of the auxiliary outputs. Select either retransmit of process variable or set point.

Operator-friendly features include automatic LED indicators to aid in monitoring and setup, as well as a calibration offset at the front panel. The Watlow Series 942 automatically stores all information in a non-volatile memory.

How to Open the 942

Before going further, open the Series 942 and pull the control chassis from its case. Here's how:

The control chassis fastens to the case with a single standard screw located on the

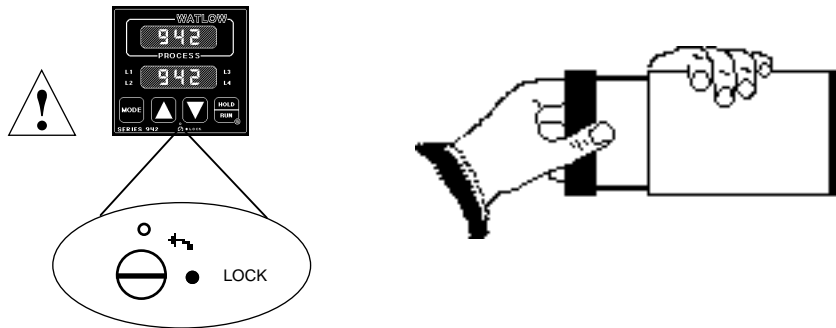

Figure 2 - How to Open the Series 942.

WARNING:
The front panel screw turns 90° only. Do not apply excessive force or turn the screw more than 90°.

Three strip connector plugs, in the rear of the control chassis, feed power and signals through the back of the case to the terminal strips. These plugs will let go as you pull.

When removing the Series 942 control from its case, pull firmly but gently. When returning the control to the case, be sure you have the top up to match the plugs with the case. The 942 will not fit in the case upside down, but check to be sure it is oriented correctly. Press the unit in firmly, then turn the front panel screw clockwise to secure it. This insures proper electrical contact.

How to Set the DIP Switches

The Watlow Series 942 has a Dual In-line Package (DIP) switch inside the control on the A007-1954 circuit board (middle board). The location of the board and switch appear below. The switches are clearly numbered. When Switch #1 is ON, the Setup parameters can be viewed but not changed. When Switch #2 is ON, it provides battery backup of the Run parameters. When the control leaves the factory, both switches are OFF.

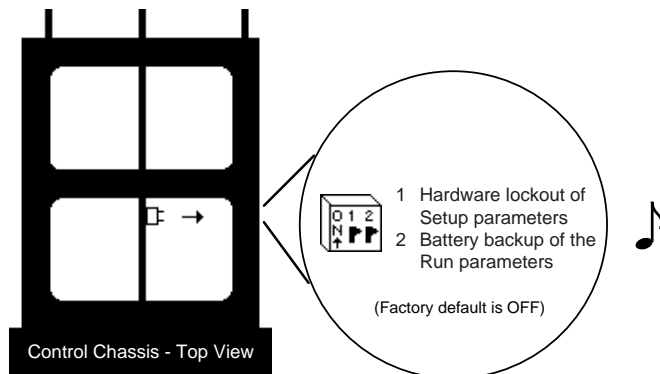

Figure 3 - DIP Switch Location and Orientation.

NOTE:
The lithium battery has a life of approximately ten years. When the battery expires, Pout and Run are affected (see Chapters 4 & 5). Return the unit to the factory for a replacement.

Chapter 2

How to Install and Wire the Series 942

System Planning

This chapter tells you how to install the Series 942. All mounting and wiring information is right here. Because Watlow controls are thoroughly tested and "burned in" before leaving the factory, the Series 942 is ready to install when you receive it.

But before you begin working, read through this chapter to gain an understanding of the entire installation. Consider sensor installation carefully. For detailed information you'll need to look at the noise reduction guidelines in the Appendix of this manual before making your panel cutout.

Installation Information

The Series 942 mounts in a panel cutout with two brackets, shipped with your control. These brackets hold the case against the front panel. The Series 942 behind-panel dimensions are 3.6" (90 mm) high by 3.6" (90 mm) wide by 6" (152 mm) deep. Figure 5 on the next page shows the dimensions of the front panel bezel. The 942 weighs 2.75 lbs. (1.25 kg) max.

For dimensional and mounting information, including the location of mounting brackets and size of the front panel cutout, see Figures 5 through 7 on the next page. Your panel's thickness can be from 0.06" (1.5 mm) to 0.25" (6.3 mm).

Installation Procedure

Follow this procedure to mount the Watlow Series 942 Temperature Control:

1. Make a panel cutout per the dimensions in Figure 6.
2. Remove the 942 from its case by turning the front panel screw 90° counter-clockwise (CCW). Grip the bezel firmly and pull the control chassis out of the case.
3. Place the case in the cutout you just made.
4. Attach the mounting brackets either to the top and bottom, or to both sides of the unit.
5. Tighten the mounting brackets securely against your panel.
6. Insert the control chassis into its case and press the bezel to seat it. Turn the front panel screw 90° clockwise (CW) to lock the control in place. The hardware installation is complete. Proceed to the wiring section from here.

NOTE:
Removing the Series 942 chassis from its case may make mounting easier.



WARNING:

The front panel screw turns 90° only. Do not apply excessive force or turn the screw more than 90°.



Dimensions

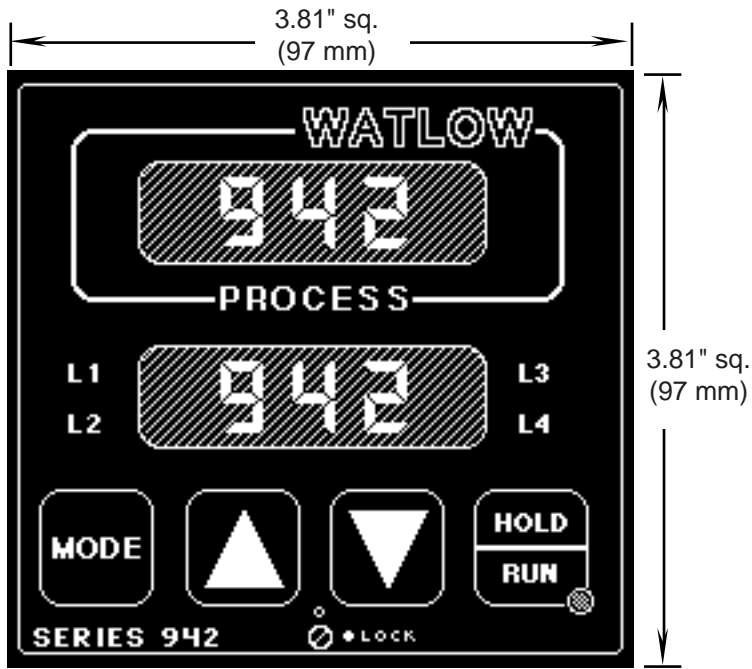

Figure 4 - Series 942 Dimensions.

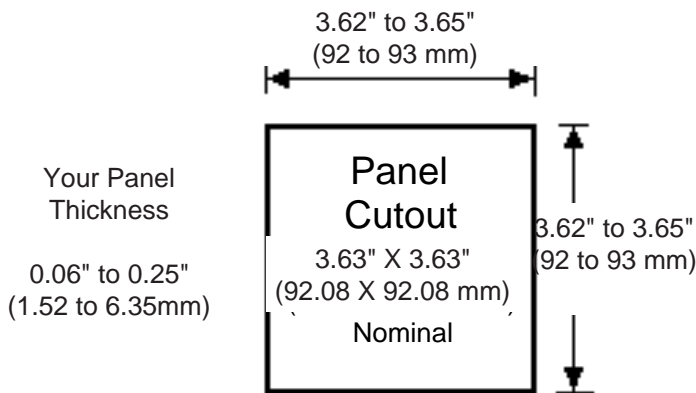
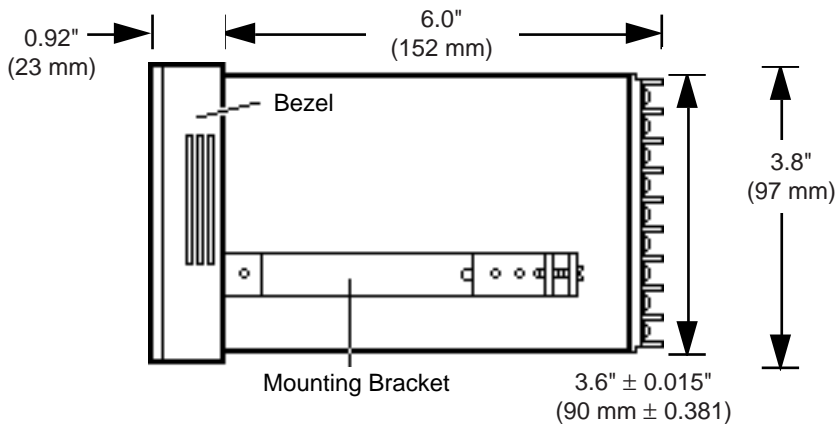

Figure 5 - Series 942 Panel Cutout Dimensions.

How to Wire the Series 942

NOTE:
For 50 or 60Hz operation, no adjustment or jumper placement is necessary.

The Series 942 wiring is illustrated by model number option. **Check the terminal designation sticker** on the control and compare your model number to those shown here and to the model number breakdown in the Appendix of this manual.

Series 942 internal circuits appear "inside" the line drawing of the 942, while connections and terminal designations appear "outside" the line drawing. All outputs are referenced to a de-energized state. The final wiring figure is a typical system example.

When you apply power without sensor inputs on the terminal strip, the Series 942 displays "- - -" in the Upper display, and Er7 in the Lower display. This error indicates an open sensor or A/D error. Remove power to the control and connect the sensor properly, see Page 10. All wiring and fusing must conform to the National Electric Code and to any locally applicable codes as well.

Figure 6 -
120 VAC Power
Wiring.

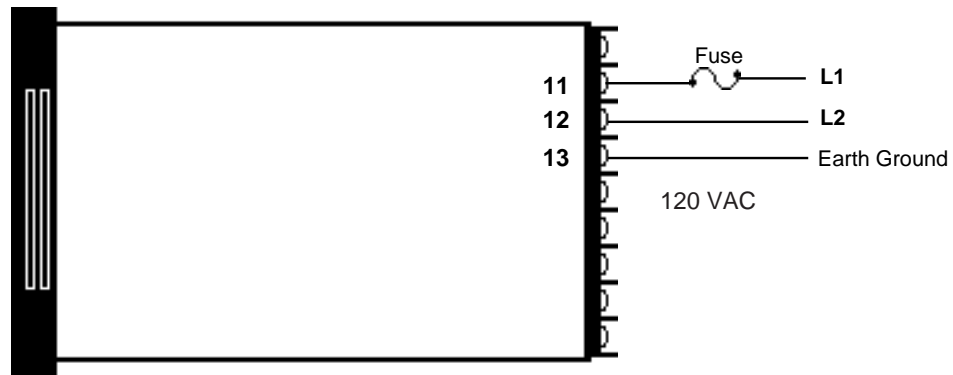

CAUTION:

To avoid potential electric shock, use National Electric Code (NEC) safety practices when wiring and connecting this unit to a power source and to electrical sensors or peripheral devices.



Figure 7 -
240 VAC Power
Wiring.

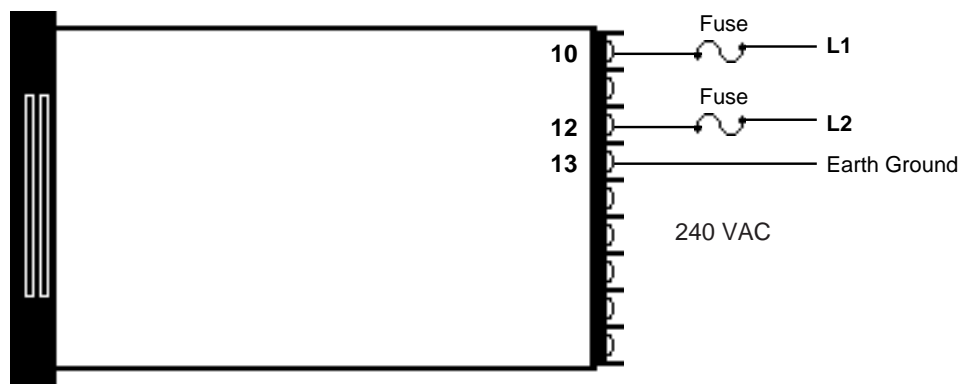

Sensor Installation Guidelines

We suggest you mount the sensor at a location in your process or system where it reads an average temperature. Put the sensor as near as possible to the material or space you want to control. The sensor should be thermally insulated from the sensor mounting.

Thermocouple Input

Model # 942A - **1** _ _ _ - _ 000 942A - **3** _ _ _ - _ 000
 942A - **2** _ _ _ - _ 000 942A - **4** _ _ _ - _ 000

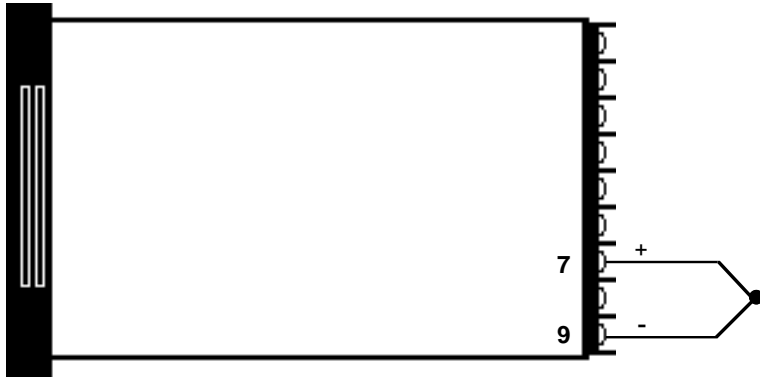

Figure 8 - Thermocouple Input Wiring.

You must use an isolated or ungrounded thermocouple, if an external device with a non-isolated circuit common is connected to the 4-20mA or 0 - 5VDC output.

Extension wire for thermocouples must be of the same alloy as the thermocouple itself to limit errors.

RTD, 2 or 3 Wire

Model # 942A - **2** _ _ _ - _ 000 942A - **3** _ _ _ - _ 000

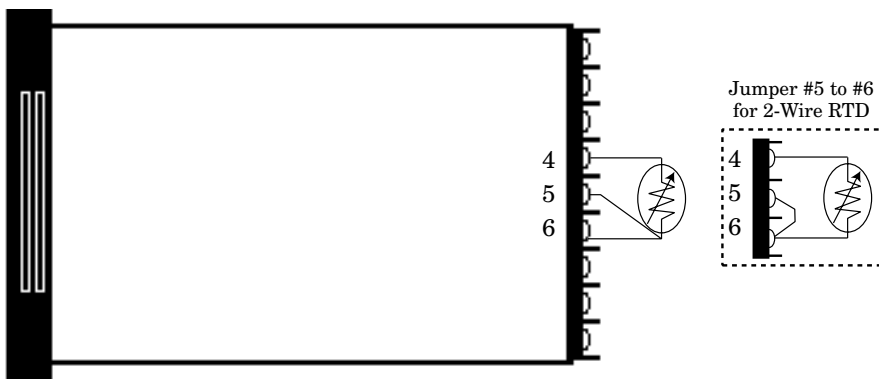

Figure 9 - 2 or 3 wire RTD Input Wiring.

Long lead lengths create electrical resistance. There will be approximately +2°C input error for every 1Ω of lead length resistance, when using a two wire RTD. The resistance, when added to the resistance of the RTD element, will result in erroneous input to the instrument. To overcome this problem, use a three wire RTD sensor, which compensates for lead length resistance. When extension wire is used for a three wire RTD, all three extension wires must have the same electrical resistance. (i.e. same gauge, copper stranded).

Input Wiring

When using a process input such as 0 - 5VDC or 4 - 20mA, the rL and rH settings scale the display to match the measured range of the process signal.

An example of this is: A pressure transducer operates over a range of 0 - 300 PSI, delivering a 4 - 20mA output signal for this range. By setting rL = 0 and rH = 300, the Series 942 now displays a direct reading of pressure.

0 - 5VDC Process Input

Model # 942A - **2** _ _ _ - _ 000

942A - **3** _ _ _ - _ 000

Figure 10 -
0 - 5VDC Process
Input Wiring.

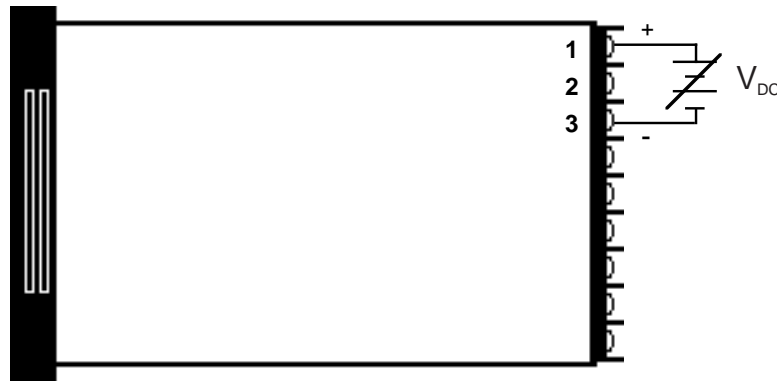

NOTE:
When using a
0 - 5VDC process
input, the input
impedance is
100K Ω .

4 - 20mA Process Input

Model # 942A - **2** _ _ _ - _ 000

942A - **3** _ _ _ - _ 000

Figure 11 -
4 - 20mA Process
Input Wiring.

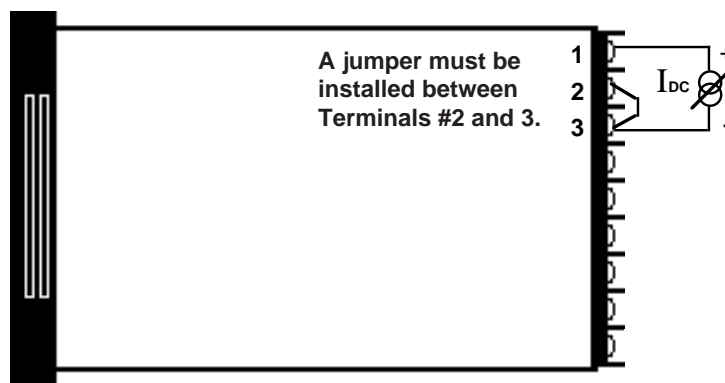

NOTE:
When using a
4 - 20mA process
input, the input
impedance is 249 Ω .

Solid State Relay With Contact Suppression, Output 1

Model # 942A - _ **B** _ _ - _ 000

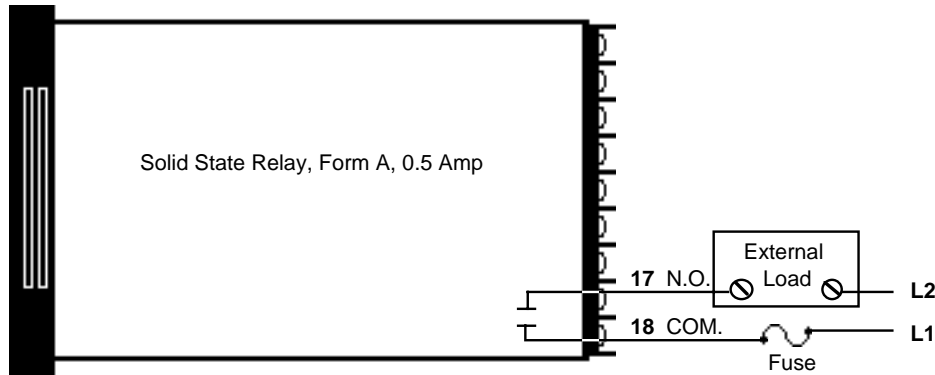

Figure 12 - Solid State Relay With Contact Suppression, Output 1 Wiring.

NOTE:
This output is supplied with an arc suppression snubber across the output terminals. High impedance loads may remain energized even though the output device is turned OFF.

Solid State Relay With Contact Suppression

Watlow's solid state relay changes state at zero volts, which is "zero-cross switching." They are also optically isolated, which means the output circuitry is energized by infrared light striking a photosensitive device. This results in a virtual absence of electrically generated noise, and provides electrical isolation between the input and output. For use in switching mercury relays or small AC loads. **Off state impedance is 20KΩ minimum.**

Switched DC Output (Open Collector), Output 1

Model # 942A - _ **C** _ _ - _ 000

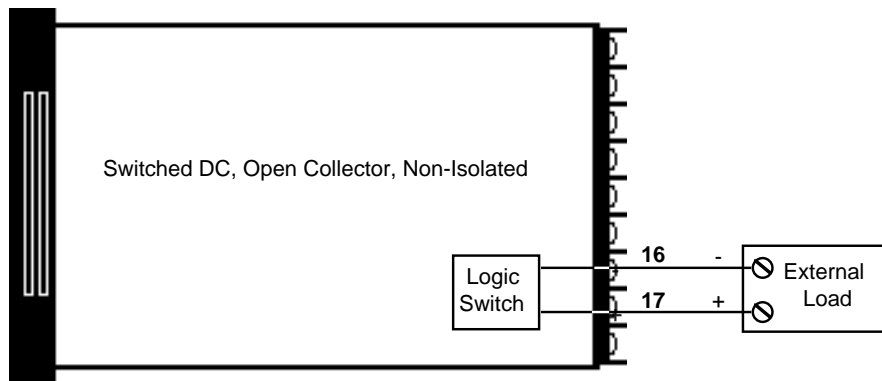

Figure 13 - Switched DC (Open Collector), Output 1 Wiring.

Switched DC

Watlow's solid state switch is a low current DC output (open collector) used to switch an external power switching device such as an SSR or an electromechanical relay. The input specifications of the power switching device must match those listed for the SS switch output. The power switching device must provide isolation between the SS switch output and load power since the SS switch output is a non-isolated output. Minimum load resistance is 500Ω. Available current is 22mA maximum. Typical voltage drop across a 1KΩ load is 12 to 19 volts.

Output 1 Wiring

Mechanical Relay, 6 Amp, Form C, Output 1

Model # 942A - **D** - - - 000

Figure 14 -
6 Amp Mechanical
Relay, Output 1
Wiring.

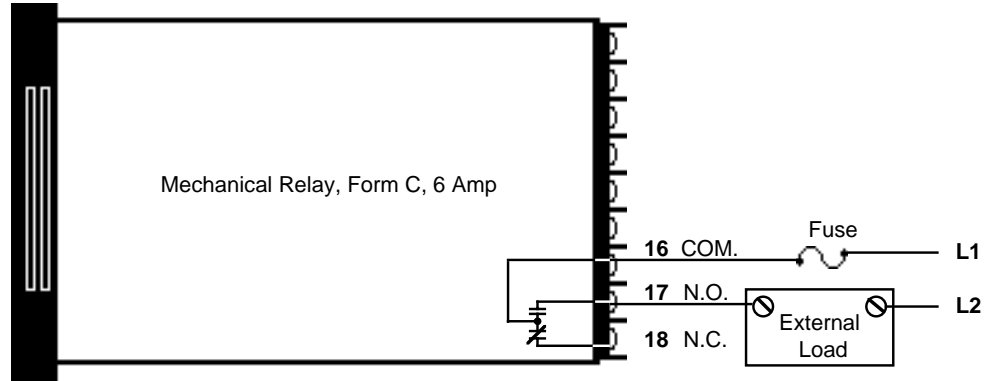

NOTE:

This output is supplied with an arc suppression snubber across the output terminals. High impedance loads may remain energized even though the output device is turned OFF.

Mechanical Relay

The electromechanical relay is an electrical and mechanical device with moving parts. When power is applied to the relay solenoid, contact closure is created through movement of the "common" contact of the relay.
Off state impedance is 20KΩ minimum.

Process, 0 - 10VDC, Output 1

Model # 942A - **E** - - - 000

Figure 15 -
Process, 0 - 10VDC,
Output 1 Wiring.

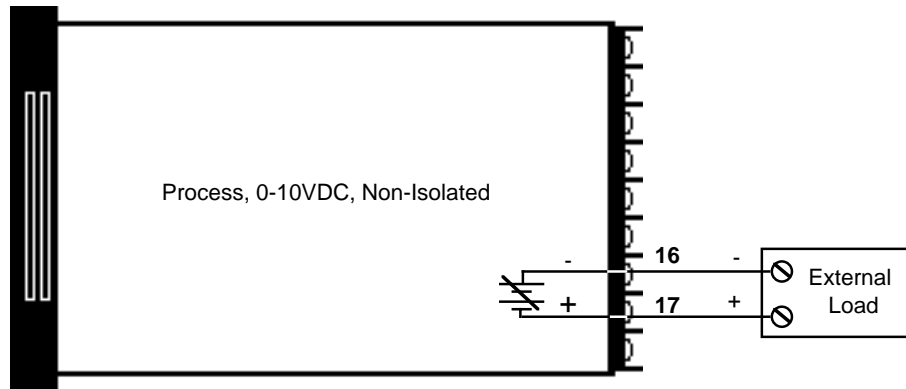

Process Output

Proportional value determined by the control to balance the sensor input and set point. This value will fall between 0 - 10VDC depending on the thermal characteristics of the system.
Load impedance is 10KΩ minimum.

Process, 4 - 20mA, Output 1

Model # 942A - _ **F** _ _ - _ 000

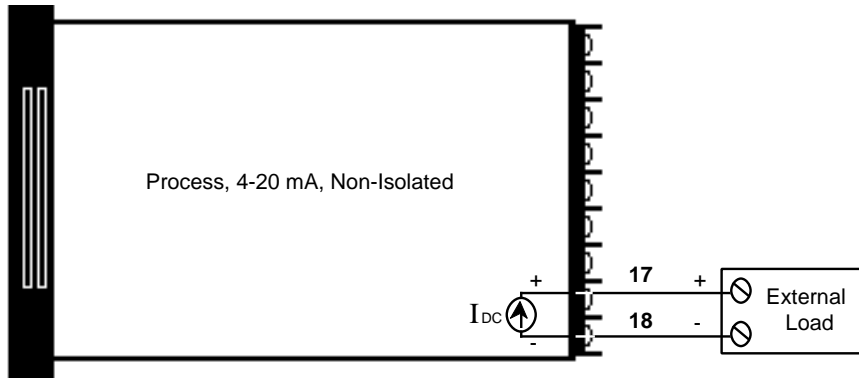

Figure 16 -
Process, 4 - 20mA,
Output 1 Wiring.

Process Output

Proportional value determined by the control to balance the sensor input and set point. This value will fall between 4 - 20mA depending on the thermal characteristics of the system.

Load impedance is 600Ω maximum.

Process, 0 - 20mA, Output 1

Model # 942A - _ **G** _ _ - _ 000

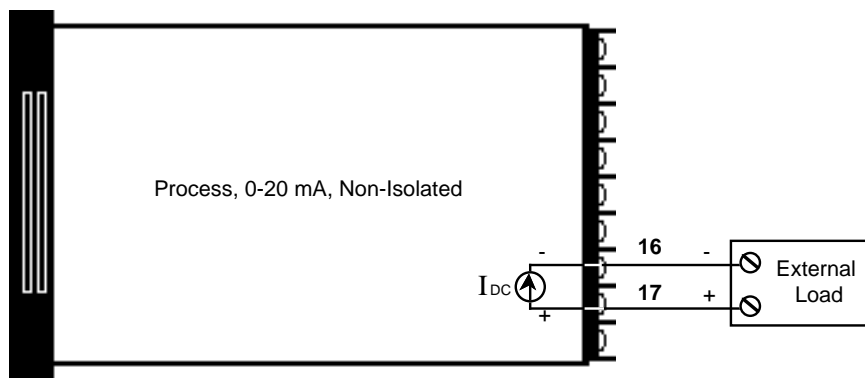

Figure 17 -
Process, 0 - 20mA,
Output 1 Wiring.

Process Output

Proportional value determined by the control to balance the sensor input and set point. This value will fall between 0 - 20mA depending on the thermal characteristics of the system.

Load impedance is 600Ω maximum.

Output 1 Wiring

Process, 0 - 5VDC, Output 1

Model # 942A - _ H _ _ - _ 000

Figure 18 -
Process, 0 - 5VDC,
Output 1 Wiring.

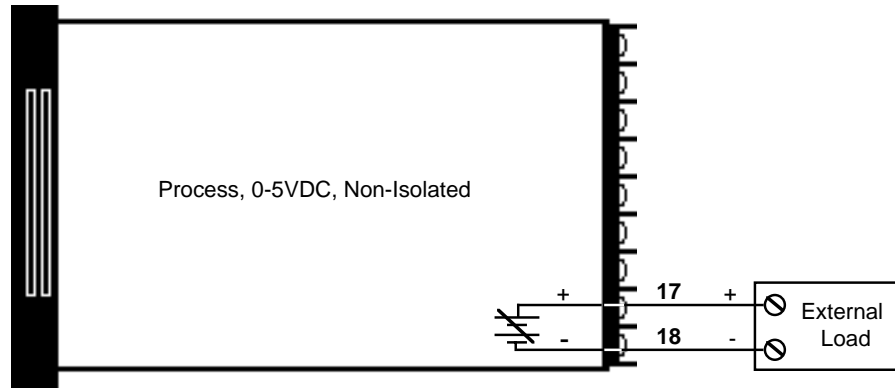

Process Output

Proportional value determined by the control to balance the sensor input and set point. This value will fall between 0 - 5VDC depending on the thermal characteristics of the system. **Load impedance is 10KΩ minimum.**

Solid State Relay Without Contact Suppression, Output 1

Model # 942A - _ K _ _ - _ 000

Figure 19 -
Solid State Relay
Without Contact
Suppression, Output
1 Wiring.

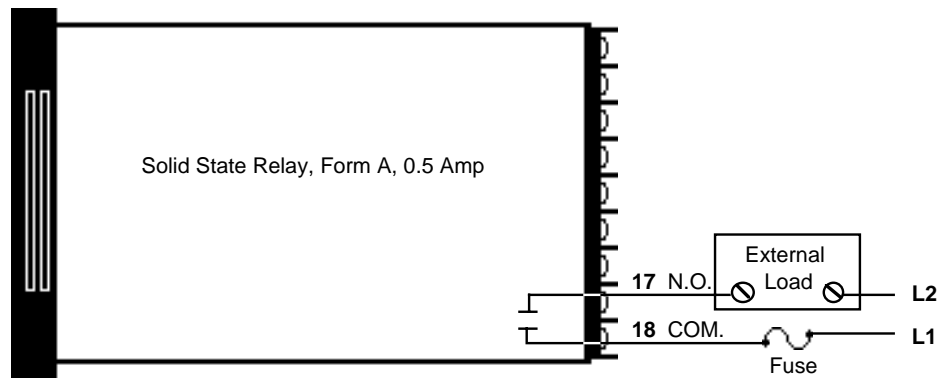

Solid State Relay Without Contact Suppression

Watlow's solid state relay changes state at zero volts, which is "zero-cross switching." They are also optically isolated, which means the output circuitry is energized by infrared light striking a photosensitive device. This results in a virtual absence of electrically generated noise, plus output to input electrical isolation. **Off state impedance is nearly infinite and should be used to switch high impedance non-inductive loads.**

Solid State Relay With Contact Suppression, Output 2

Model # 942A - _ _ **B** _ - _ 000

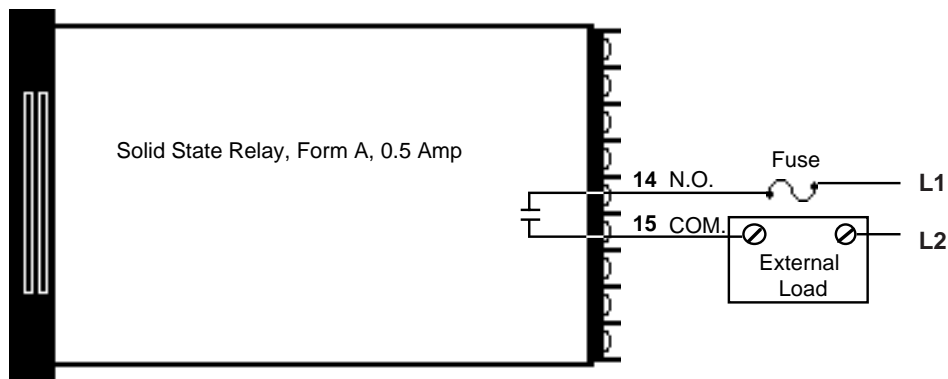

Figure 20 - Solid State Relay With Contact Suppression, Output 2 Wiring.

Solid State Relay With Contact Suppression

Watlow's solid state relay changes state at zero volts, which is "zero-cross switching." They are also optically isolated, which means the output circuitry is energized by infrared light striking a photosensitive device. This results in a virtual absence of electrically generated noise, and provides electrical isolation between the input and output. For use in switching mercury relays or small AC loads. **Off state impedance is 20KΩ minimum.**

NOTE:

This output is supplied with an arc suppression snubber across the output terminals. **High impedance loads may remain energized even though the output device is turned OFF.**

Switched DC Output (Open Collector), Output 2

Model # 942A - _ _ **C** _ - _ 000

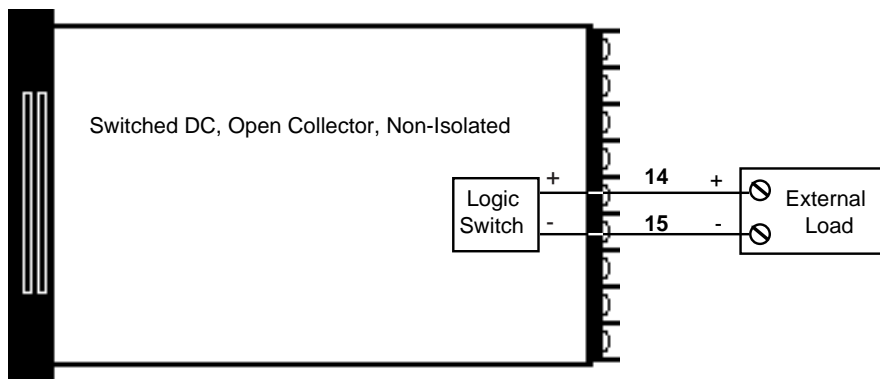

Figure 21 - Switched DC Output (Open Collector), Output 2 Wiring.

Switched DC

Watlow's solid state switch is a low current DC output (open collector) used to switch an external power switching device such as a SSR or an electromechanical relay. The input specifications of the power switching device must match those listed for the S.S. switch output. The power switching device must provide isolation between the S.S. switch output and load power since the S.S. switch output is a non-isolated output. Minimum load resistance is 500Ω. Available current is 9mA minimum and 22mA maximum.

Output 2 Wiring

Mechanical Relay, 6 Amp, Form A, Output 2

Model # 942A - _ _ **D** _ - _ 000

Figure 22 -
6 Amp Mechanical
Relay, Output 2
Wiring.

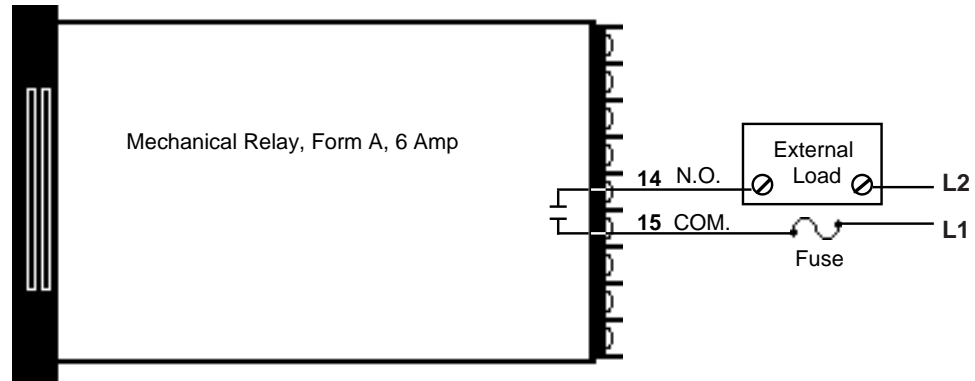

NOTE:
This output is supplied with an arc suppression snubber across the output terminals. High impedance loads may remain energized even though the output device is turned OFF.

Mechanical Relay

The electromechanical relay is an electrical and mechanical device with moving parts. When power is applied to the relay solenoid, contact closure is created through movement of the "common" contact of the relay. **Off state impedance is 20K Ω minimum.**

Solid State Relay Without Contact Suppression, Output 2

Model # 942A - _ _ **K** _ - _ 000

Figure 23 -
Solid State Relay
Without Contact
Suppression,
Output 2 Wiring.

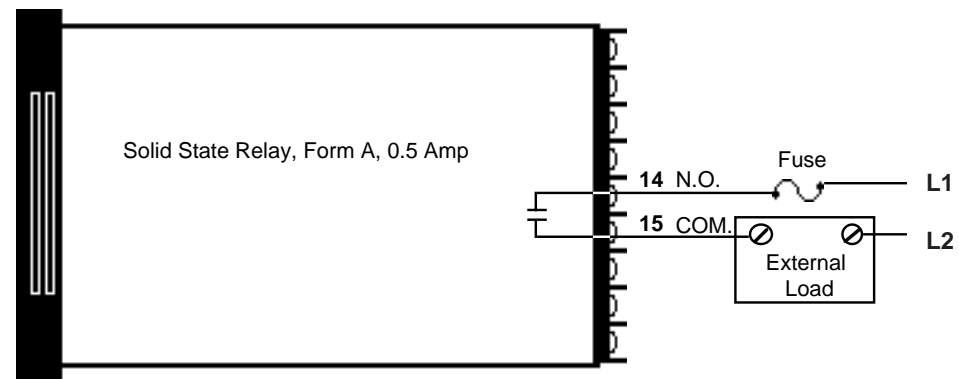

Solid State Relay Without Contact Suppression

Watlow's solid state relays change state at zero volts, which is "zero-cross switching." They are also optically isolated, which means the output circuitry is energized by infrared light striking a photosensitive device. This results in virtual absence of electrically generated noise, while providing output to input electrical isolation. **Off state impedance is nearly infinite and should be used to switch high impedance non-inductive loads.**

For more information on alarms, alarm jumper selection and events, see Chapter 6.

Mechanical Relay

The electromechanical relay is an electrical and mechanical device with moving parts. When power is applied to the relay solenoid, contact closure is created through movement of the "common" contact of the relay. **Off state impedance is 20KΩ minimum.**

Mechanical Relay, 6 Amp, Single Form A or B, Auxiliary Output

Model # 942A- _ _ _ **1** - _ 000

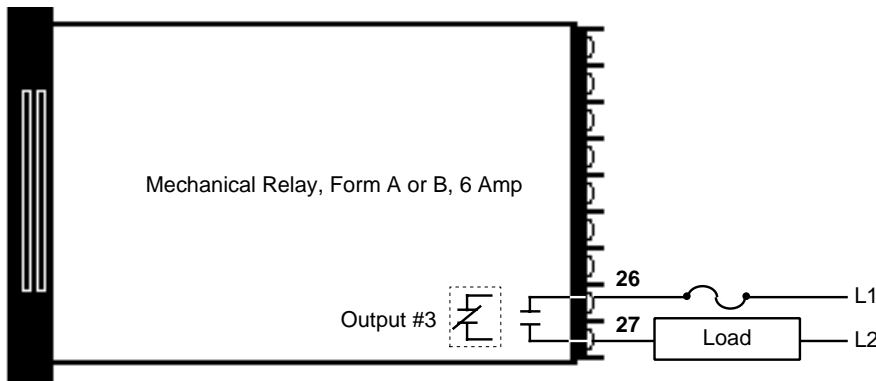

Figure 24 - Auxiliary Option 1 Wiring.

NOTE:
This output is supplied with an arc suppression snubber across the output terminals. High impedance loads may remain energized even though the output device is turned OFF.

Mechanical Relay, 6 Amp, Dual Form A or B, Auxiliary Output

Model # 942A- _ _ _ **2** - _ 000

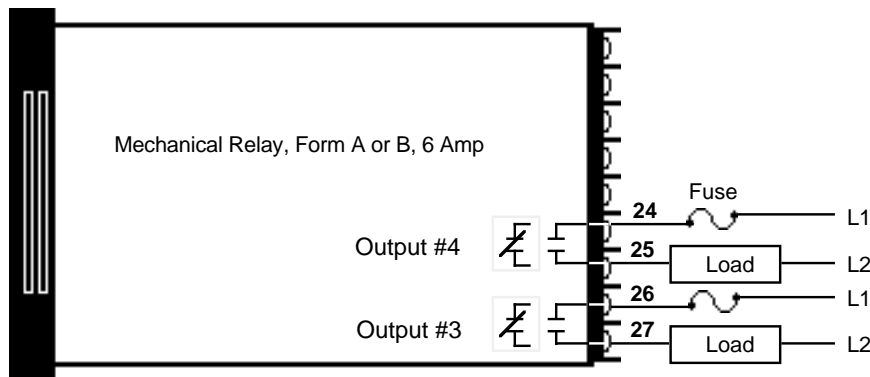

Figure 25 - Auxiliary Option 2 Wiring.

Auxiliary Wiring

Mechanical Relay

The electromechanical relay is an electrical and mechanical device with moving parts. When power is applied to the relay solenoid, contact closure is created through movement of the "common" contact of the relay.

Mechanical Relay, 6 Amp, Form A or B/0 - 5VDC Retransmit

Model # 942A- _ _ _ **3** - _ 000

Figure 26 - Auxiliary Option 3 Wiring.

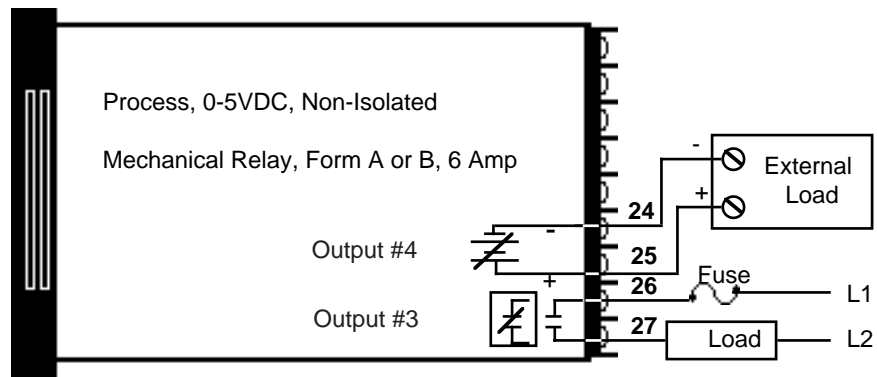

Load impedance 10K Ω minimum.

NOTE:

This output is supplied with an arc suppression snubber across the output terminals. High impedance loads may remain energized even though the output device is turned OFF.

Mechanical Relay, 6 Amp, Form A or B/4 - 20mA Retransmit

Model # 942A- _ _ _ **4** - _ 000

Figure 27 - Auxiliary Option 4 Wiring.

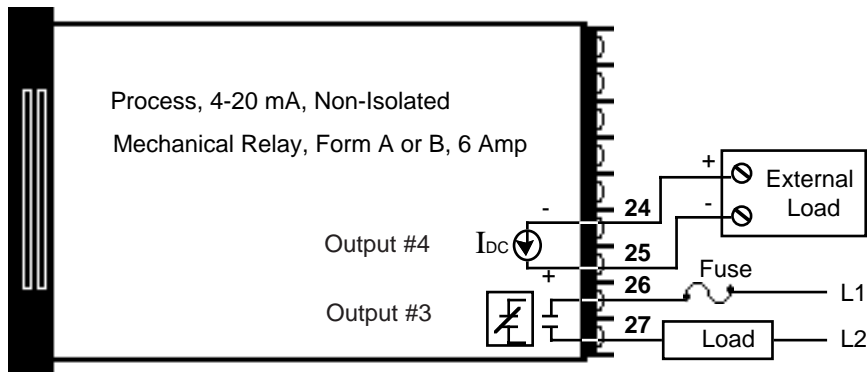

Load impedance 600 Ω maximum.

Retransmit Output

When using a retransmit output such as 0 - 5VDC or 4 - 20mA, the rL and rH settings scale the range of the retransmit output.

An example of this is: By setting rL = 0, rH = 1000 and Ot4 = PrOC a process value of 500 will result in a retransmitted signal of 2.5VDC or 12mA.

0 - 5VDC Retransmit, Auxiliary Output

Model # 942A- _ _ _ **5** - _ 000

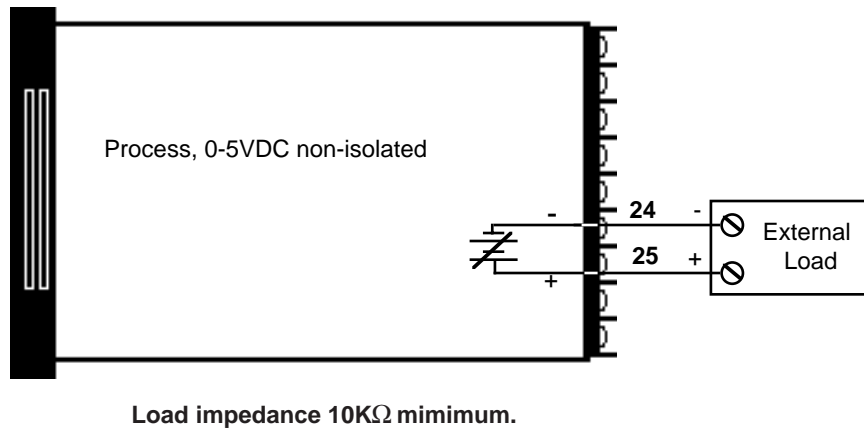

Figure 28 -
Auxiliary Option 5
Wiring.

4 - 20mA Retransmit, Auxiliary Output

Model # 942A- _ _ _ **6** - _ 000

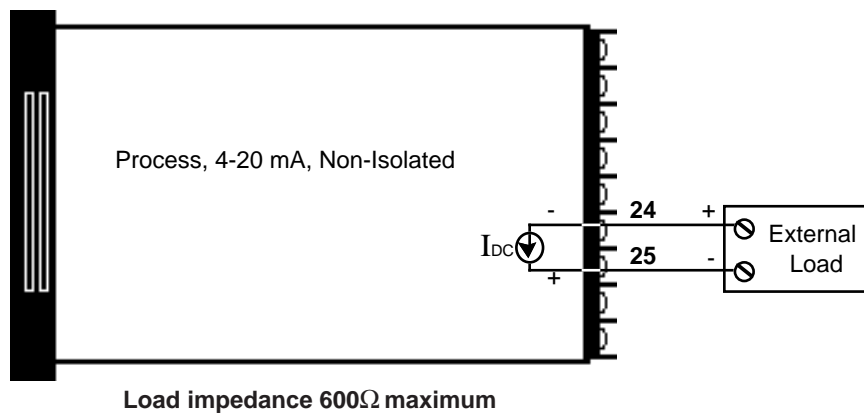

Figure 29 -
Auxiliary Option 6
Wiring.

Wiring Example



CAUTION:

All wiring and fusing must conform to the National Electric Code NFPA70. Contact your local board for additional information. Failure to observe NEC safety guidelines could result in injury to personnel.

Figure 30 - System Wiring Example



WARNING:

Watlow mercury relays are designed to be used only with resistive loads.

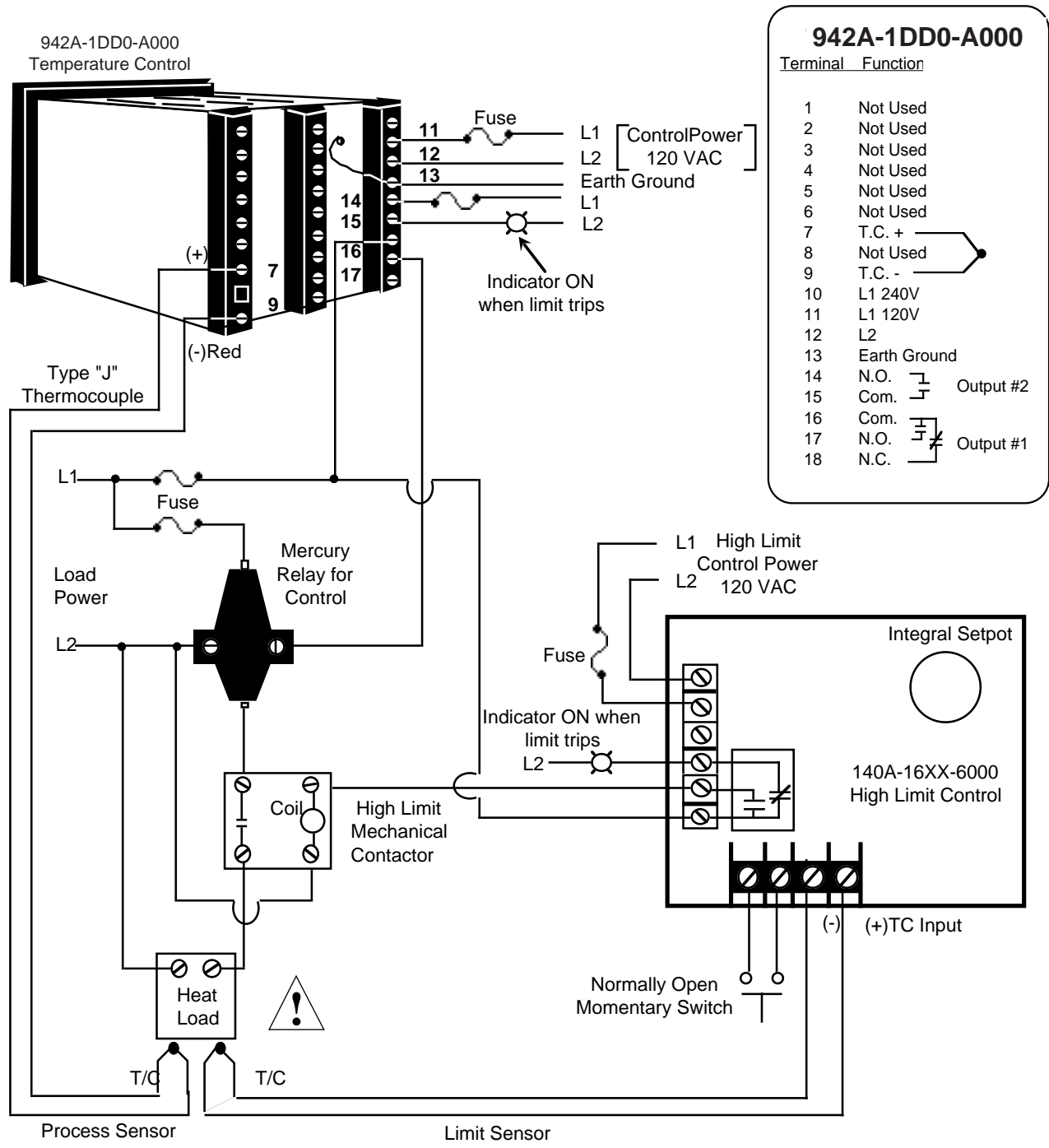

Chapter 3

How to Use the Keys and Displays

After 1 minute with no key activations, the control reverts to the process value in the Upper display and the set point in the Lower display, except when in the RUN menu.

Upper Display

Red, 0.56" (14 mm) high, seven segment, four digit LED display, indicating process variable (such as actual temperature) in addition to parameter values, or an open sensor. When powering up, the Process display will be blank for 8 seconds.

L 1 & L2

When lit, these LED's tell you when Output 1 or 2 is energized. L2 only appears if your unit has a #2 output.

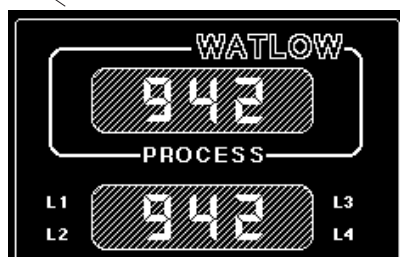

L3 & L4

When lit, these LEDs indicate an energized alarm or event condition for Output 3 or 4. Only appears on those units with auxiliary option.

Lower Display

Red 0.56" (14 mm) high, seven segment, four digit LED display, indicating the set point, menu parameters, and alarm or error codes.

UP/DOWN Keys

When pressed simultaneously for 3 seconds, the Setup Menu appears displaying the LOC parameter. At the LOC parameter, continue to press the UP/DOWN keys, and the Calibration Menu will appear.

UP Key

Increases the value of the displayed parameter. A light touch increases the value by one. Hold the key down to increase the value at a rapid rate. New data is self entering in 5 seconds.

DOWN Key

Decreases the value of the displayed parameter. A light touch decreases the value by one. Hold the key down to decrease the value at a rapid rate. New data is self entering in 5 seconds.

HOLD/RUN Key

Pressed once, it clears any latched alarms without altering the HOLD/RUN status. To run or halt a program see Chapter 5 for details.



MODE Key

Steps the control through the Operating menu; also, automatically enters data changes before proceeding to the next parameter.

Front Panel Locking Screw

Secures or releases the control chassis from its case.

HOLD/RUN LED

Lit when the control is RUNNING. When blinking, press the HOLD/RUN key again to begin RUNNING.

Figure 31 - Series 942 Keys and Displays.

Chapter 4

How To Setup The Series 942

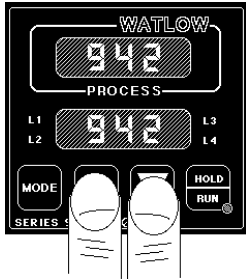

Figure 32 - Entering the Setup Menu.

Setting up the Series 942 is a simple process. First configure the 942's features to your application in the Setup Menu, enter values in the Operating Menu, and program your control. Use the MODE key to move through the menus and the UP/DOWN keys to select data. At this point, enter the Calibration menu, and select US or SI under the **dFL** parameter if necessary. Rate, reset and °F appear with US, and integral, derivative and °C appear with SI. See Appendix III.

Entering the Setup Menu

The Setup Menu displays the parameters that configure the Series 942's features to your application. Enter the Setup Menu by pressing the UP/DOWN keys simultaneously for 3 seconds. The Lower display shows the LOC parameter, and the Upper display shows its current level. All keys are inactive until you release both keys. You can reach the LOC parameter from anywhere except the Run menu. While in the Setup menu, all outputs are OFF.

Use the MODE key to cycle through the menu, and the UP/DOWN keys to select Setup data. You will not see all parameters in this menu, depending on the unit's configuration, model number, and LOC parameter. After stepping through the menu it returns to the control set point parameter under the Operation menu.

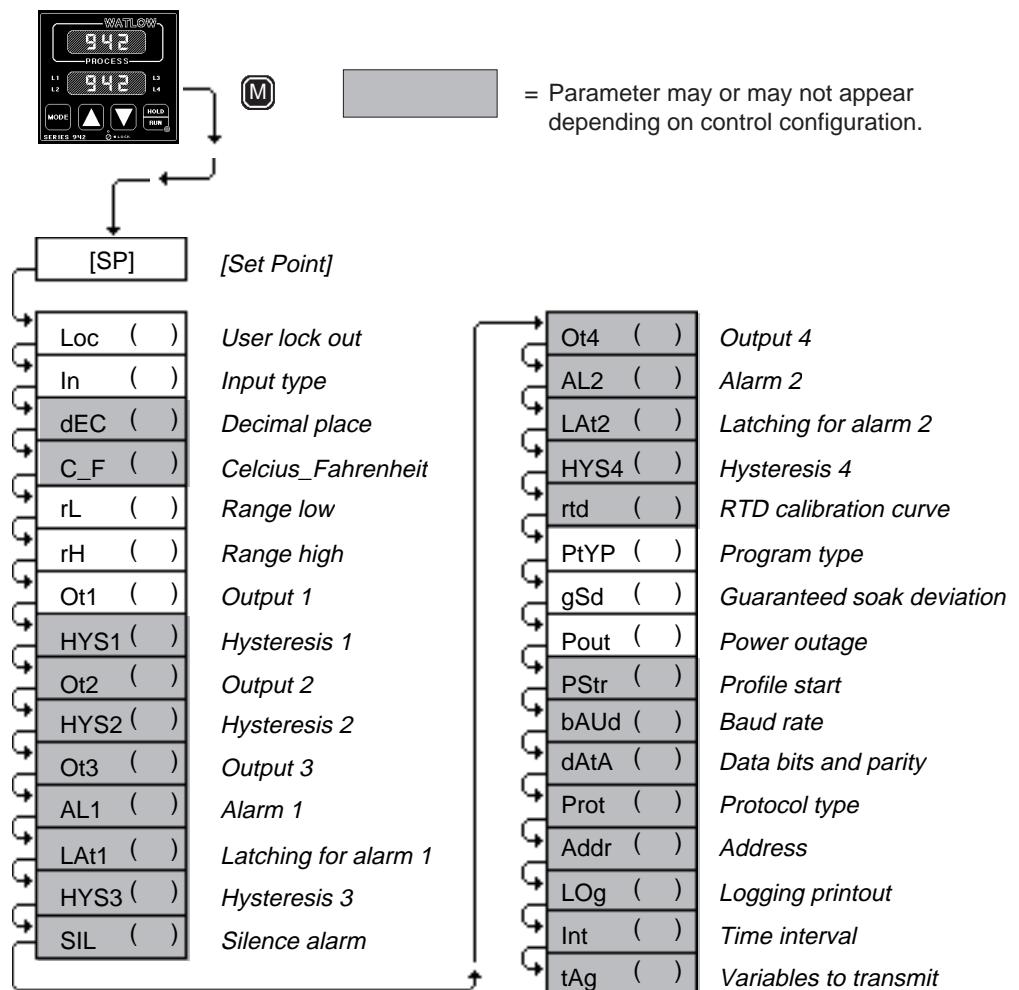

Figure 33 - The Setup Menu.

NOTE:
The rL and rH parameters are used to scale the display for process inputs, and/or will scale the retransmit range for process output. rL and rH also limit the range of the set point.

Setup Parameters

When you are at the top of the menu, the Series 942 displays the user level of operation in the Upper display, and the LOC parameter in the Lower display.

When you press the MODE key, the **value** of the next parameter appears in the Upper display, and the parameter appears in the Lower display.

Lock: Selects the level of operator lockout.
Range: 0 - 3 **Default:** 0

LOC

LOC 0: All operating parameters may be viewed or changed.

LOC 1: Locks out the PID parameters. Set point, process value and events are the only visible operating parameters, set point **is** adjustable in this level. A profile can be viewed, changed, run or halted.

LOC 2: Locks out the PID parameters and the Program menu. Set point, process value and events are the only visible operating parameters, set point **is** adjustable. A profile can be run or halted but **not** viewed or changed.

LOC 3: Locks out the entire Operating and Program menus. Set point and process value are the only visible operating parameters, set point **is not** adjustable. A profile can be run or halted but not viewed or changed.

Input: Selects the sensor input type. Only those input types which are compatible with your unit will appear. See the model number information for your type. **Changing this parameter erases all profile steps and defaults them to an End step.**
Range: J, K (appears as H), t, n, c, r, S, b, Pt2, rtd1, rtd.1, 0-5, 420 **Default:** J or r

In

Decimal: Selects the location of the decimal point for all process related data. This parameter only appears if the In parameter is 0-5 or 420.
Range: 0, 0.0, 0.00 **Default:** 0

dEC

Celsius _ Fahrenheit: Selects the units of temperature measurement for the control. This parameter only appears if In = T/C or RTD input. **Changing this parameter erases all profile steps and defaults them to an End step.**
Range: C or F **Default:** F

C _ F

Range Low: Selects the low end of the set point range. See the model number and specification information in the Appendix, and Table 1 on Page 26 for sensor range values. Also used to set the low end of the process input and/or the low end of the range for the retransmit output. 0.0VDC and 4mA represent Range Low (rL) for process inputs and outputs. Process inputs and outputs are linearly scaled between rL and rH. **Changing this parameter erases all profile steps and defaults them to an End step.**

rL

Range: Sensor range low to rH **Default:** Low limit of sensor type

Range High: Selects the high end of the set point range. See the model number and specification information in the Appendix, and Table 1 on Page 26 for your sensor range values. Also used to set the high end of the process input and/or the high end of the range for the retransmit output. 5.0VDC and 20mA represent Range High (rH) for process inputs and outputs. Process inputs and outputs are linearly scaled between rL and rH. **Changing this parameter erases all profile steps and defaults them to an End step.**

rH

Range: Sensor range high to rL **Default:** High limit of sensor type

Setup

Ot1

Output 1: Selects the output action for the primary output. Action in response to the difference between set point and process variable. Select ht (heat) for reverse acting or select CL (cool) for direct acting.

Range: ht, CL **Default:** ht

HYS1

Hysteresis 1: Selects the switching hysteresis for Output 1 when Pb1 = 0 (ON/OFF). See Page 29 for the Pb1 parameter.

Range: 1°F - 999°F 0.1°F - 99.9°F **Default:** 3°F
1°C - 540°C 0.1°C - 54.0°C
1Unit - 999 Units 0.1 Units - 99.9 Units

Ot2

Output 2: Selects the output action for the secondary output. Action in response to the difference between set point and process variable. Select ht (heat) for reverse acting or select CL (cool) for direct acting. This parameter only appears if you have a secondary output. If Ot1 = ht: **Range:** CL, no

If Ot1 = CL: **Range:** ht, no **Default:** CL

HYS2

Hysteresis 2: Selects the switching hysteresis for Output 2 when 0 = (ON/OFF) under the Pb 2 parameter. See Page 29 for the Pb2 parameter. This parameter only appears if you have a secondary output.

Range: 1°F - 999°F 0.1°F - 99.9°F **Default:** 3°F
1°C - 540°C 0.1°C - 54.0°C
1Unit - 999 Units 0.1 Units - 99.9 Units

Ot3

Output 3: Selects Output 3 as an alarm or an event. This parameter only appears if you have at least one auxiliary output.

Range: AL, Ent, no **Default:** AL

AL1

Alarm 1: Determines whether the alarm type for Alarm 1 is process or deviation. A process alarm is set at an absolute temperature to prevent over/under-range. This parameter only appears if you ordered auxiliaries with your unit and Ot3 = AL. See Chapter 6 for more information on alarms.

Range: Pr, dE **Default:** Pr

LA1

Latching 1: Selects whether Alarm 1 is latching or non-latching. Latching alarms must be cleared before the alarm output will reset. Non-latching automatically resets the alarm output when the condition clears. This parameter only appears if your unit has auxiliary outputs and Ot3 = AL. See Chapter 6.

Range: LAt or nLA **Default:** nLA

HYS3

Hysteresis 3: Selects the switching hysteresis for Output 3 and appears if Ot3 = AL, and your unit has an auxiliary output.

Range: 1°F - 999°F 0.1°F - 99.9°F **Default:** 3°F
1°C - 540°C 0.1°C - 54.0°C
1Unit - 999 Units 0.1 Units - 99.9 Units

SIL

SIL: Selects alarm silencing (inhibit) for Output 3. This parameter only appears when AL1 = dE, and Ot3 = AL. For more information see Chapter 6.

Range: On or OFF **Default:** OFF

Output 4: Selects Output 4 as an alarm (AL) or event (Ent) if Output 4 is an auxiliary output. Selects Output 4 as retransmit of Process (PrOC) or Set Point (StPt) if Output 4 is a retransmit output. Hardware must also be present. Scaling of the retransmit output is determined by rL and rH.

Ot4

Auxiliary Output:

Range: AL, Ent, no **Default:** AL

Retransmit Output:

Range: PrOC, StPt, no **Default:** PrOC

Alarm 2: Determines whether the alarm type for Output 4 is process or deviation. A process alarm is set at an absolute temperature to prevent over/underrange. This parameter only appears if you ordered auxiliaries with your unit and Ot4 = AL.

AL2

Range: Pr, dE **Default:** Pr

Latching 2: Selects whether Alarm 2 is latching or non-latching. Latching alarms must be cleared before the alarm output will reset. Non-latching automatically resets the alarm output when the condition clears. This parameter only appears if Ot4 = AL, and if your unit has alarms. **Range:** LAt or nLA **Default:** nLA

LAt2

Hysteresis 4: Selects the switching hysteresis for Auxiliary 2 and appears if Ot4 = AL, and your unit has an auxiliary output.

HYS4

Range: 1°F - 999°F 0.1°F - 99.9°F **Default:** 3°F
 1°C - 540°C 0.1°C - 54.0°C
 1Unit - 999 Units 0.1 Units - 99.9 Units

RTD: Selects the RTD calibration curve for RTD inputs. This parameter appears if In = rtd or rt.d. JIS = 0.003916Ω/Ω°C, DIN = 0.003850Ω/Ω°C.

rtd

Range: din or JIS **Default:** din

Program Type: Selects the program type as time based (ti) or ramp rate (rAtE) in degrees per minute. **Changing this parameter erases all profile steps and defaults them to an End step.**

PtYP

Range: ti (time based) or rAtE (ramp rate) **Default:** ti

Guaranteed Soak Deviation: Guarantees the actual temperature is being controlled within a window around the set point. If this deviation is exceeded, the time clock stops and the lower display alternately flashes gSd and the current parameter until the process variable returns within the window. See Chapter 5 for more information on the guaranteed soak deviation parameter.

gSd

Example: A guaranteed soak deviation of 3 equals a ± 3° deviation about the current set point.

0 = Guaranteed soak deviation **not** active. >0 = Active guaranteed soak

Range: 0°F - 99°F 0.0°F - 9.9°F **Default:** 0°
 0°C - 55°C 0.0°C - 5.5°C
 0 - 99 Units 0.0 - 9.9 Units

Power Outage: Selects the profile status upon power restoration following a power loss. By selecting continue (Cont), your profile continues running from where it was interrupted. HOLd maintains the last set point prior to power loss. Abort (Abrt) quits running the profile, displays OFF in the lower display, and turns off all outputs. When Abrt or HOLd are selected, the lower display alternately flashes Pout and the current parameter. rSET (Reset) causes a start from the beginning of your profile. Press the HOLD/RUN key to clear.

Pout

Range: Cont (Continue), HOLd, Abrt (Abort), rSET (Reset) **Default:** Cont

Setup

PStr	<p>Profile Start: Selects whether the profile starts at the current set point value or the current process value. Range: Proc or StPt Range: StPt</p>
bAud	<p>Baud: Represents the current baud rate for serial communications. This parameter appears if your Series 942 has communications. Range: 300, 600, 1200, 2400, 4800, 9600 Default: 1200</p>
dAtA	<p>Data: Allows the user to select the data bits and parity for communication. This parameter appears if your Series 942 has communications. Range: 7 o = 7 data bits and odd parity Default: 7 o 7 E = 7 data bits and even parity 8 n = 8 Data bits and no parity</p>
Prot	<p>Protocol: Selects the communication protocol. This parameter appears if your Series 942 has communications. FULL = ANSI X3.28 2.2 - A.3 On = XON - XOFF Range: FULL or On Default: FULL</p>
Addr	<p>Address: Selects the address for this unit if Prot = FULL. This parameter appears if your Series 942 has communications. Range: 0 to 31 Default: 0</p>
Log	<p>Log: Selects the data logging function for a printout of the data. This parameter appears if your Series 942 has communications, and Prot = On. Range: On or OFF Default: OFF</p>
Int	<p>Interval: Selects the time interval for the logging function. This parameter appears if your Series 942 has communications, Prot = On, and Log = On. Range: 0.0 to 60.0 minutes Default: 0.0</p>
tAg	<p>Tag: Selects what variables are to be transmitted out during the data logging function. This parameter appears if your Series 942 has communications, Prot = On, and Log = On. P = Process S = Set Point A = Auxiliary Status Range: PSA, PS-, P-A, P--, -SA, -S-, --A, --- Default: ---</p>

Table 1- Input Ranges

Input Type	Sensor Range Low	Sensor Range High
J	32°F/0°C	1382°F/750°C
K (appears as H)	-328°F/-200°C	2282°F/1250°C
t	-328°F/-200°C	662°F/350°C
n	32°F/0°C	2282°F/1250°C
Pt2	32°F/0°C	2543°F/1395°C
c	797°F/425°C	4200°F/2315°C
r	32°F/0°C	2642°F/1450°C
S	32°F/0°C	2642°F/1450°C
b	*32°F/0°C	3092°F/1700°C
rtd (1°)	-328°F/-200°C	1112°F/600°C
rt.d (0.1°)	-99.9°F/-99.9°C	392.0°F/200.0°C
0-5 (VDC)	-5.00/-50.0/-500	35.00/350.0/3500
420 (mA)	-5.00/-50.0/-500	35.00/350.0/3500

NOTE:

* b t/c: Useable range is suggested to be 1598 to 3092°F or 870 to 1700°C. Range is at 32° to allow using at low temperatures without range low sensor errors.

Use this page as a master copy for configuring your Series 942.
Do not enter any values here; make photocopies instead.

Setup

**Table 2 -
Setup Menu Parameters and Descriptions.**

Setup Parameters	Value	Range	Factory Default
LOC		0 to 3	0
In		J, K (appears as H), t, n, c, r, S, b, Pt2, rtd1, rtd.1, 0-5, 420 Dependent on model number.	J or r
dEC		0, 0.0, or 0.00 Dependent on input type.	0
C _ F		C or F Will not appear if In = 0-5 or 420.	F
rL		rL to rH	Input selection dependent.
rH		rH to rL	Input selection dependent.
Ot1		ht or CL	ht
HYS1		1°F - 999°F, 1°C - 540°C, 1U - 999U 0.1°F - 99.9°F, 0.1°C - 54.0°C, 0.1U - 99.9U	3°F
Ot2		ht, CL or no	CL
HYS2		1°F - 999°F, 1°C - 540°C, 1U - 999U 0.1°F - 99.9°F, 0.1°C - 54.0°C, 0.1U - 99.9U	3°F
Ot3		AL, Ent or no	AL
AL1		Pr or dE	Pr
LAt 1		LAt or nLA Dependent on AL 1 = Pr or dE.	nLA
HYS3		1°F - 999°F, 1°C - 540°C, 1U - 999U 0.1°F - 99.9°F, 0.1°C - 54.0°C, 0.1U - 99.9U	3°F
SIL		On or OFF	OFF
Ot4		AL, Ent, no, ProC or StPt	AL or ProC
AL 2		Pr or dE	Pr
LAt 2		LAt or nLA	nLA
HYS4		1°F - 999°F, 1°C - 540°C, 1U - 999U 0.1°F - 99.9°F, 0.1°C - 54.0°C, 0.1U - 99.9U	3°F
rtd		JIS or din	din
PtYP		ti or rAtE	ti
gSd		0 - 99°F, 0 - 55°C, 0 - 99U 0.0 - 9.9°F, 0.0 - 5.5°C, 0.0U - 9.9U	0
POUt		Cont, HOlD, Abt or rSET	Cont
PStr		Proc or StPt	StPt
bAUd		300, 600, 1200, 2400, 4800, 9600	1200
dAtA		7 o = Odd parity, 7 E = Even parity 8 n = 8 data bits and no parity	7 o
Prot		FULL or On	FULL
Addr		0 to 31	0
Log		On or OFF	OFF
Int		0.0 to 60.0 minutes	0.0
tag		PSA, PS-, P-A, P--, -SA, -S-, --A, --- P = Process, S = Set point A = Auxiliary Status	---

Operation

Operation Menu

In the Operation menu, the 942 operates as a digital set point control. Select a set point and the 942 attains that value on a non-linear ramp. If your unit has auxiliary outputs programmed as events, they can be selected as ON or OFF. All outputs are turned OFF when set point is set to OFF.

NOTE:
The Upper display always returns to the process value after 1 minute without key strokes.

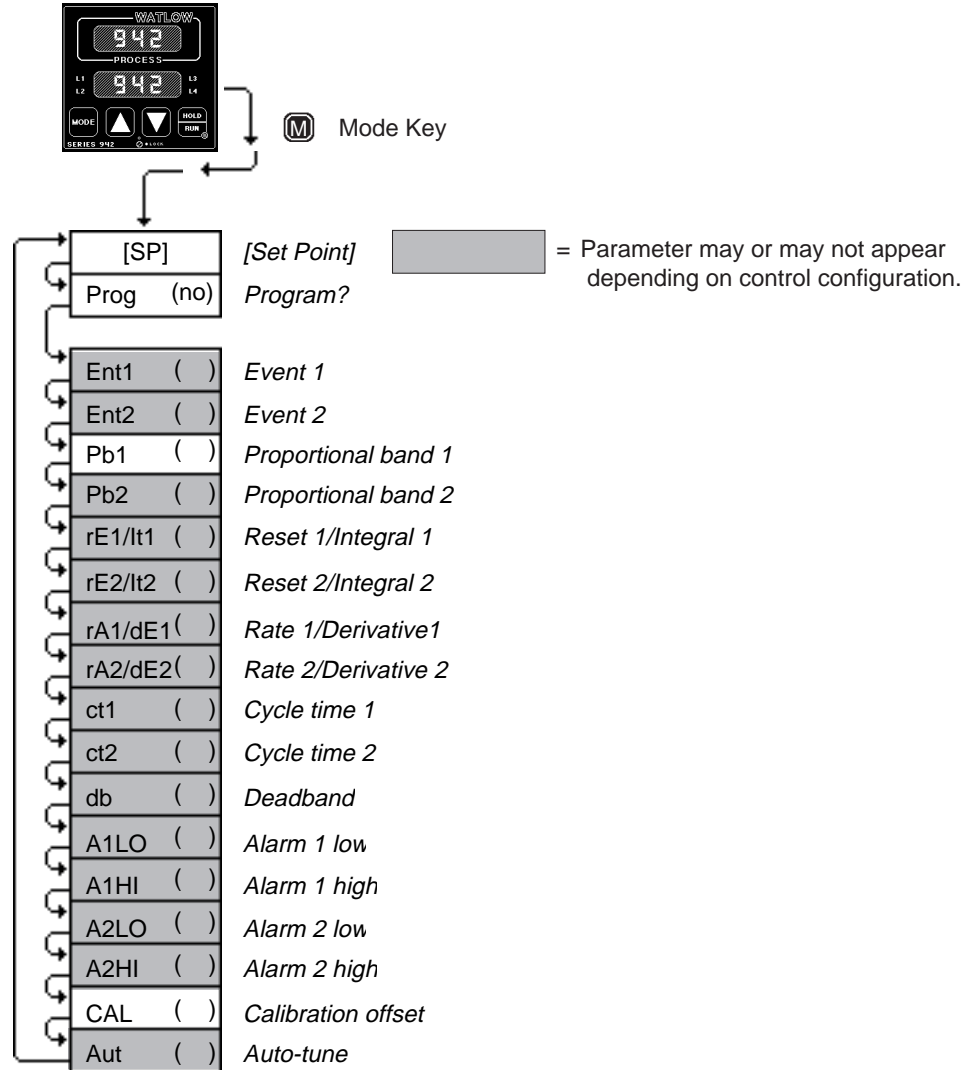

Figure 34 - The Operation Menu.

Operation Parameters

[SP]

Set Point: Sets the operating set point for the control outputs. "SP" does not appear, the control set point **value** will. Decrementing the set point below rL displays OFF in the lower display. This disables all outputs except deviation alarm outputs, which remain energized.

Prog (no)

Range: OFF/ rL to rH **Default:** Dependent on input range

Ent1

Program: Select whether you want to enter the Program menu or enter the Operation menu. By selecting no, you continue to the Operation menu.

Range: YES or no **Default:** no

Ent1: Select whether Event 1 (Output 3) is ON or OFF. When a profile is complete or has been put on hold, it holds at its previous state. Only appears if Ot3 = Ent, and your unit has auxiliary outputs. For more information on events see Chapter 6.

Range: On or OFF **Default:** OFF

Ent2: Select whether Event 2 (Output 4) is ON or OFF. When a profile is complete or has been put on hold, it will hold at its previous state. This parameter only appears if Ot4 = Ent, and your unit has auxiliary outputs. For more information on events see Chapter 6. **Range:** On or OFF **Default:** OFF

Ent2

Proportional Band 1: A proportional band expressed in degrees or process units, or % of span, within which a controller proportioning function is active for Output 1. When Pb1 = 0, it functions as an ON/OFF control. The switching differential is then determined by the HYS1 parameter. If dFL = US: **Range:** 0 to 999°F/0 to 555°C/0 to 999 Units; 0.0 to 99.9°F/0.0 to 55.5°C/0.0 to 99.9 Units **Default:** 25°F/2.5°F
If dFL = SI: **Range:** 0 to 999.9% of span **Default:** 3.0%
Span is defined as the operating range of the input sensor or rL to rH if the input type is 0-5 or 420.

Pb1

Proportional Band 2: A proportional band expressed in degrees or process units, or in % of span, within which a controller proportioning function is active for Output 2. When Pb2 = 0, it functions as an ON/OFF control. The switching differential is determined by the HYS2 parameter. This parameter will not appear if your unit does not have a secondary output or Ot2 = no. If dFL = US: **Range:** 0 to 999°F/0 to 555°C/0 to 999 Units; 0.0 to 99.9°F/0.0 to 55.5°C/0.0 to 99.9 Units **Default:** 0°
If dFL = SI: **Range:** 0 to 999.9% of span **Default:** 0.0%

Pb2

Reset /Integral1: A reset (integral) control action for Output 1 automatically eliminating offset, or "droop," between set point and actual process temperature in a pro-portional control. Will not appear if your unit does not have a secondary output, or Pb1 = 0. **Reset Range:** 0.00 to 9.99 repeats/minute **Integral Range:** 0 and 00.1 to 99.9 minutes/repeat **Default:** 0.00

rE1/It1

Reset /Integral 2: A reset (integral) control action for Output 2 that automatically eliminates offset, or "droop," between set point and actual process temperature in a proportional control. This parameter will not appear if your unit does not have a secondary output, or Pb 2 = 0, or if Ot 2 = no. **Reset Range:** 0.00 to 9.99 repeats/minute **Integral Range:** 0 and 00.1 to 99.9 minutes/repeat **Default:** 0.00

rE2/It2

Rate /Derivative 1: The rate (derivative) function for Output 1 of the Series 942. The rate is determined by how fast the error is changing. This parameter will not appear if Pb 1 = 0. **Range:** 0.00 to 9.99 minutes **Default:** 0.00

rA1/dE1

Rate/Derivative 2: Rate (derivative) function for Output 2. Rate is determined by how fast the error is changing. Does not appear if your unit does not have a secondary output, Pb 2 = 0, or Ot 2 = no. **Range:** 0.00 to 9.99 min. **Default:** 0.00

rA2/dE2

Cycle Time 1: Expressed in seconds, time for a controller to complete one ON/OFF cycle for Output 1. Time between successive turn ons. This parameter will not appear if Pb 1 = 0, or Output 1 is a process output.

Range: 1 to 60 seconds

Default: 5

Ct1

Cycle Time 2: Expressed in seconds, time for a controller to complete one ON/OFF cycle for Output 2. Time between successive turn ons. This parameter will not appear if your unit does not have a secondary output, Pb 2 = 0, or Ot 2 = no.

Range: 1 to 60 seconds

Default: 5

Ct2

Dead Band: The area between Output 1 and 2 where no heating or cooling takes place in a heat/cool proportional control. This parameter only appears if your unit is set up as a ht/CL or CL/ht unit. **Range:** ±0 to 99°F/0 to 55°C/0 to 99 Units; or ±0.0 to 9.9°F/0.0 to 5.5°C/0.0 to 9.9Units **Default:** 0

db

Alarm 1 Low: Represents the low process alarm or low deviation alarm for Alarm 1. This parameter only appears if you have an auxiliary output and Ot3 = AL. See the model number. If AL 1 = Pr: **Range:** rL to A1HI **Default:** rL
If AL 1 = dE: **Range:** 0 to -999°F/0 to -999°C/0 to -999 Units **Default:** -999°F

A1LO

Operation

A1HI	<p>Alarm 1 High: This parameter represents the high process alarm or high deviation alarm for Alarm 1. This parameter appears if your unit has an auxiliary output and Ot3 = AL. See the model number. If AL 1 = Pr: Range: A1LO to rH Default: rH AL 1 = dE: Range: 0 to -999°F/0 to -999°C/0 to -999 Units Default: -999°F</p>
A2LO	<p>Alarm 2 Low: Represents the low process alarm or low deviation alarm for Alarm 2. Appears if your unit has an auxiliary output and Ot4 = AL. See the model number. If AL 2 = Pr: Range: rL to A2HI Default: rL If AL 2 = dE: Range: 0 to -999°F/0 to -999°C/0 to -999 Units Default: -999°F.</p>
A2HI	<p>Alarm 2 High: Represents the high process alarm or high deviation alarm for Alarm 2. Appears if your unit has an auxiliary output and Ot4 = AL. See the model number. If AL 2 = Pr: Range: A2LO to rH Default: rh If AL 2 = dE: Range: 0 to -999°F/0 to -999°C/0 to -999 Units Default: -999°F</p>
CAL	<p>Calibration Offset: Adds or subtracts degrees from the input signal. Range: -99°F to 99°F/-55°C to 55°C/99 Units to 99 Units; or -99.9°F to 99.9°F/-55.5°C to 55.5°C Default: 0</p>
AUt	<p>Auto-Tune: This parameter initiates auto-tune for Output 1 in the heating mode only. This parameter appears if Ot1 = ht. For more information on Tuning see Chapter 6. Range: 0 = off, 1 = slow, 2 = medium, 3 = fast Default: 0</p>

Table 3 - Operation Menu Parameters and Descriptions.

Operation Parameters	Value	Range	Factory Default
SP		OFF/rL to rH	75°F
Prog		YES or no	no
Ent1		On or OFF	OFF
Ent2		On or OFF	OFF
Pb1		If dFL = US: 0 - 999°F/0 - 555°C/0 - 999 Units 0 - 99.9°F/0 - 55.5°C/0 - 99.9 Units If dFL = SI: 0 to 999.9% 0 = ON/OFF control. HYS1 = switch. diff.	25°F 3.0%
Pb2		Same as Pb1. Will not appear if Ot 2 = no.	0°
rE1/It1		Reset: 0.00 to 9.99 repeats/min. Integral: 0 and 00.1 to 99.9 min./repeat 0.00 = no reset. Will not appear if Pb1 = 0.	0.00 repeats/min.
rE2/It2		Same as rE1. Will not appear if Pb2 = 0.	0.00 repeats/min.
rA1/dE1		0.00 to 9.99 min. 0.00 = No Rate. Will not appear if Pb1 = 0	0.00 min.
rA2/dE2		Same as rA1. Will not appear if Pb2 = 0.	0.00 min.
Ct1		1 to 60 seconds Won't appear if Pb1 = 0, or output 1 is 4-20	5 seconds
Ct2		1 to 60 seconds Will not appear if Pb2 = 0 or Ot2 = no.	5 seconds
db		± 0 - 99°F/± 0 - 55°C/0 - 99 Units. ± 0.0 - 9.9°F/0.0 - 5.5°C/0.0 - 9.9 Units Appears if ht/CL or CL/ht.	0
A1LO - Deviation dE Process Pr		-999° to 0° rL to A1HI Appears if auxiliary output and Ot3 = AL.	-999° rL
A1HI - Deviation dE Process Pr		0° to 999° A1LO to rH Appears if auxiliary output and Ot3 = AL.	999° rH
A2LO- Deviation dE Process Pr		-999° to 0° rL to A2HI Appears if auxiliary output and Ot4 = AL.	-999 rL
A2HI- Deviation dE Process Pr		0° to 999° A2LO to rH Appears if auxiliary output and Ot4 = AL.	999° rH
CAL		± 99°F/± 55°C/± 99 Units	0
AUt		0 to 3	0

Chapter 5

How to Program & Run the Series 942

We begin this chapter by introducing the Program menu. Each parameter is clearly defined. A description of a few Series 942 features follows, along with a sample profile to experiment with programming the Series 942. You will quickly grasp the necessary terms and concepts by entering and observing your profiles. Enter your profile values in the Master Step Chart at the end of the chapter.

PROGRAM Menu

Create your profiles here in the Program menu. Your profile can have up to 24 steps. Choose one step type per step.



Figure 35 - The Program Menu.

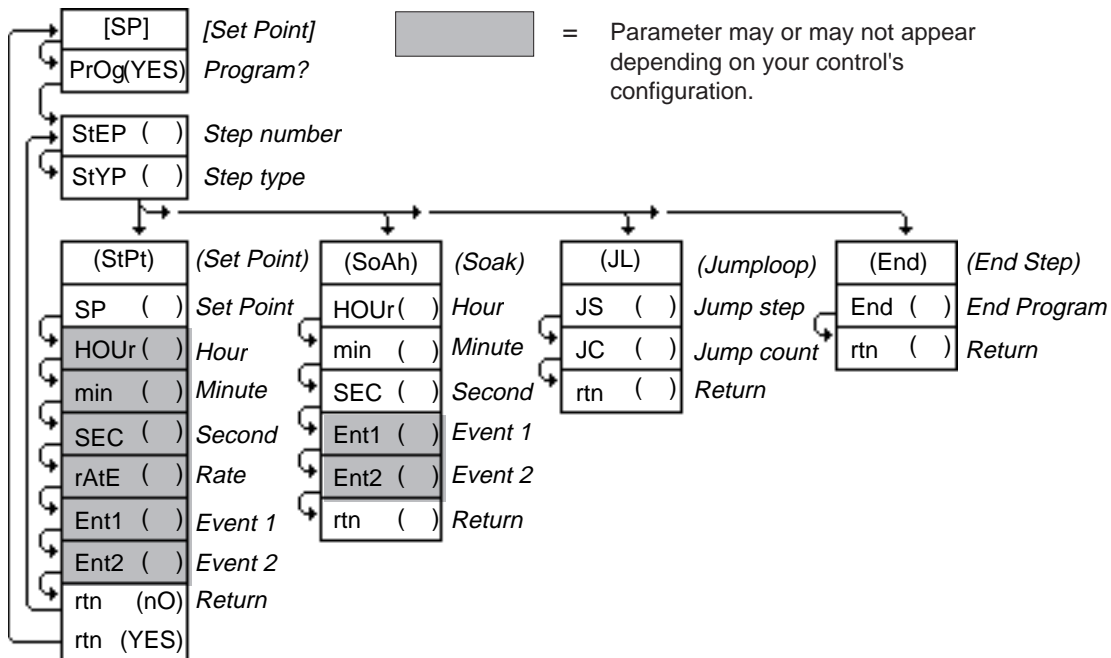

Program

Program Parameters

Prog (YES)

Program: Select whether you want to enter the Operation or the Program menu. Selecting YES continues into the Program menu.

Range: YES or no **Default:** no

StEP

Step: Represents the current step of the profile to be edited or viewed. When selecting Step 1, you will not see the JL step type.

Range: 1 to 24 **Default:** 1 then automatic increment

StYP

Step Type: Choose from four different step types.

Range: StPt, SoAh, JL or End **Default:** End

(StPt)

Set Point Step (StPt) : The following parameters are associated with the set point step.

SP

Set Point: Represents the temperature the system tries to achieve. This is done linearly, producing a ramp from a beginning set point to an end set point.

Range: rL to rH **Default:** 75°F/24°C or rL value if $rL \geq 75^\circ\text{F}/24^\circ\text{C}$ or if $rH \leq 75^\circ\text{F}/24^\circ\text{C}$

HOUr

Hour: The number of hours, in combination with the Min and SEC parameters, equaling total step time to achieve the temperature under the StPt step type. This parameter only appears if PtYP = ti.

Range: 0 to 23 **Default:** 0

Min

Minutes: The number of minutes, in combination with the HOUr and SEC parameters, equaling total step time to achieve the temperature under the StPt step type. This parameter only appears if PtYP = ti.

Range: 0 to 59 **Default:** 0

SEC

Seconds: The number of seconds, in combination with the HOUr and Min parameters, equaling total step time to achieve the temperature under the StPt step type. This parameter only appears if PtYP = ti.

Range: 0 to 59 **Default:** 0

rAte

Rate: Represents the rate at which the set point changes in degrees per minute. This parameter only appears if PtYP = rAte.

Range: 0 to 360°F/0 to 200°C or 0.0 to 360.0°F/0.0 to 200.0°C **Default:** 0.0

Ent1

Event 1: Selects whether Event 1 is on or off. This parameter only appears if Ot3 = Ent.

Range: On or OFF **Default:** OFF

Ent2

Event 2: Selects whether Event 2 is on or off. This parameter only appears if Ot4 = Ent.

Range: On or OFF **Default:** OFF

rtn

Return: Select no and you return to the StEP parameter to continue programming. By selecting YES, you exit the program menu and return to the control set point.

Range: YES or no **Default:** no

Program

Soak (SoAh) : The following parameters are associated with the soak step.

(SoAh)

Hour: The number of hours, in combination with the Min and SEC parameters, equaling total step time to achieve the temperature under the SoAh step type. This parameter only appears if PtYP = ti.

HOUr

Range: 0 to 23 **Default:** 0

Minutes: The number of minutes, in combination with the HOUr and SEC parameters, equaling total step time to achieve the temperature under the SoAh step type. This parameter only appears if PtYP = ti.

Min

Range: 0 to 59 **Default:** 0

Seconds: The number of seconds, in combination with the HOUr and Min parameters, equaling total step time to achieve the temperature under the SoAh step type. This parameter only appears if PtYP = ti.

SEC

Range: 0 to 59 **Default:** 0

Event 1: Selects whether Event 1 is on or off. Only appears if Ot3 = Ent.

Ent1

Range: On or OFF **Default:** OFF

Event 2: Selects whether Event 2 is on or off. Only appears if Ot4 = Ent.

Ent2

Range: On or OFF **Default:** OFF

Return: Select no and you return to the StEP parameter to continue programming the 942. By selecting YES, you exit the program menu and return to the control set point.

rtn

Range: YES or no **Default:** no

Jumploop Step (JL) : The following parameters are associated with the jumploop step. When StEP = 1, JL will not appear.

(JL)

Jump Step: The Series 942 jumps backwards to any step in your file.

JS

Range: 1 to 23 **Default:** 1

Jump Count: The number of times the Series 942 jumps to the step specified by the JS (jump step) parameter. 0 = infinite number of jumps.

JC

Range: 0 to 100 **Default:** 0

Return: Select no and you return to the StEP parameter to continue programming the Series 942. By selecting YES, you exit the program menu and return to the control set point. **Range:** YES or no **Default:** no

rtn

End Step (End) : The following parameters are associated with the end step.

(End)

End: When HOLd is selected, the control and auxiliary outputs are enabled and maintain the same state as in the last set point and/or soak step before the End step was encountered. When selected as OFF, the control and auxiliary outputs (except for deviation alarms) are de-energized and OFF is shown in the lower display. When selected as OFFA, the control outputs are de-energized and OFF is shown in the lower display. Deviation alarms are inactive (relay energized) and process alarms are active (relay energized in non-alarm conditions).

End

Range: HOLd or OFF **Default:** HOLd

Return: Select no and you return to the StEP parameter to continue programming the 942. By selecting YES, you exit the program menu and return to the control set point. **Range:** YES or no **Default:** no

rtn

RUN Menu

Running a Series 942 Profile

You can run your Series 942 profile from anywhere except the Setup menu. Press the HOLD/RUN key. The RUN LED begins flashing, and the lower display flashes and asks what StP (step) to begin on. Use the UP/DOWN key to enter the step and press the HOLD/RUN key once again, your profile begins, and the RUN LED is lit. If the HOLD/RUN key is not pressed twice within 1 minute, the RUN function will abort. **While the profile is RUNNING, you can only view the RUN menu.** Press the MODE key to advance you through the RUN menu. For more information on Pout (power outages) see Page 25.

Resume a Profile

To resume a halted profile, press the HOLD/RUN key once. Press the MODE key to advance to the rESU parameter, and press the HOLD/RUN key again, the profile resumes, and the RUN LED is lit. You can only resume at the **exact** step you left off on. If you halt a running profile and make changes, you **cannot** resume running. The rESU parameter only appears when a running profile is halted.





- To **Run** your profile... Press the  key twice.
- To **Stop** a running profile... Press the  key once.
- To **Resume** a halted profile... Press the  key, press the  key to advance to the rESU parameter, and press the  key.

Figure 36 - The Run Menu.



Master Step Chart

Chart 1 - Master Step Chart

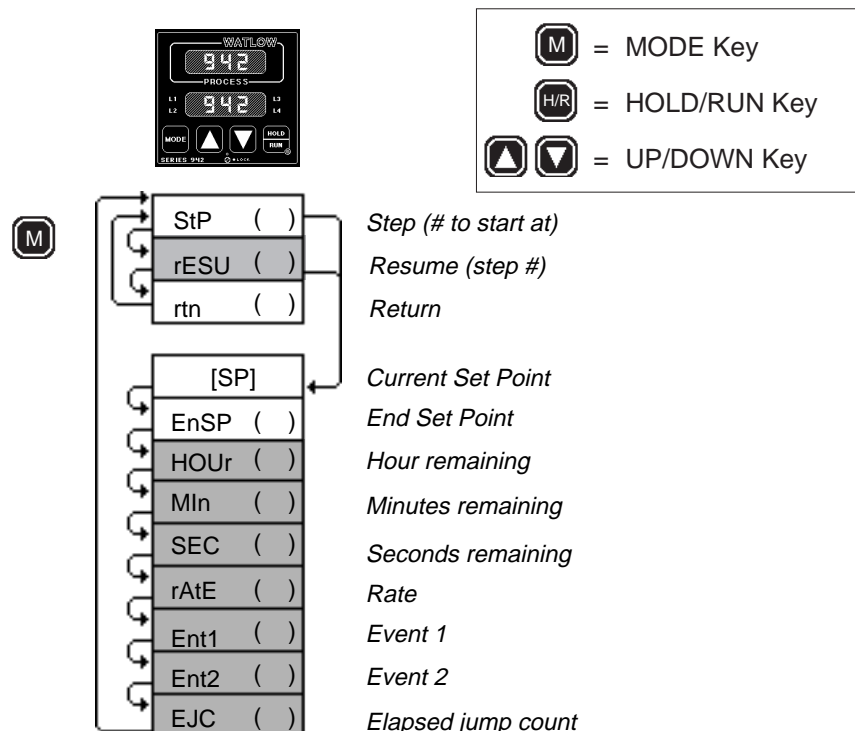
Make photocopies, keep original clean.

Step #	<input checked="" type="checkbox"/> Step Type	Values	Time			On	Events	OFF
	<input type="checkbox"/> StPt	SP	HOuR	Min	SEC	Ent1	Ent2	
			rAtE					
	<input type="checkbox"/> SoAh		HOuR	Min	SEC	Ent1	Ent2	
	<input type="checkbox"/> JL	JS	JC					
	<input type="checkbox"/> End	OFF		OFFA	HOLd			

Step #	<input checked="" type="checkbox"/> Step Type	Values	Time			On	Events	OFF
	<input type="checkbox"/> StPt	SP	HOuR	Min	SEC	Ent1	Ent2	
			rAtE					
	<input type="checkbox"/> SoAh		HOuR	Min	SEC	Ent1	Ent2	
	<input type="checkbox"/> JL	JS	JC					
	<input type="checkbox"/> End	OFF		OFFA	HOLd			

Step #	<input checked="" type="checkbox"/> Step Type	Values	Time			On	Events	OFF
	<input type="checkbox"/> StPt	SP	HOuR	Min	SEC	Ent1	Ent2	
			rAtE					
	<input type="checkbox"/> SoAh		HOuR	Min	SEC	Ent1	Ent2	
	<input type="checkbox"/> JL	JS	JC					
	<input type="checkbox"/> End	OFF		OFFA	HOLd			

Step #	<input checked="" type="checkbox"/> Step Type	Values	Time			On	Events	OFF
	<input type="checkbox"/> StPt	SP	HOuR	Min	SEC	Ent1	Ent2	
			rAtE					
	<input type="checkbox"/> SoAh		HOuR	Min	SEC	Ent1	Ent2	
	<input type="checkbox"/> JL	JS	JC					
	<input type="checkbox"/> End	OFF		OFFA	HOLd			

Step #	<input checked="" type="checkbox"/> Step Type	Values	Time			On	Events	OFF
	<input type="checkbox"/> StPt	SP	HOuR	Min	SEC	Ent1	Ent2	
			rAtE					
	<input type="checkbox"/> SoAh		HOuR	Min	SEC	Ent1	Ent2	
	<input type="checkbox"/> JL	JS	JC					
	<input type="checkbox"/> End	OFF		OFFA	HOLd			

Step #	<input checked="" type="checkbox"/> Step Type	Values	Time			On	Events	OFF
	<input type="checkbox"/> StPt	SP	HOuR	Min	SEC	Ent1	Ent2	
			rAtE					
	<input type="checkbox"/> SoAh		HOuR	Min	SEC	Ent1	Ent2	
	<input type="checkbox"/> JL	JS	JC					
	<input type="checkbox"/> End	OFF		OFFA	HOLd			

Event Outputs

One of the features of the Series 942 is its capability for two event outputs. An "event output" is simply a pre-programmed ON/OFF event per profile step. The event may turn any number of peripheral devices ON or OFF to assist you in controlling your process, system or environment.

For instance, in an environmental chamber, you might wish to circulate air at a given time in your profile for one or more steps. You might want to turn lights on or off, or signals, or lock out your humidifier, or you could activate a video recorder.

Ent1 and Ent2 are not visible under the Operation menu unless your unit has auxiliary outputs and you Setup Ot3 and Ot4 as events.

To select auxiliary outputs as events, enter the Setup menu by pressing the UP/DOWN keys simultaneously for 3 seconds. The LOC parameter appears. Press the MODE key until you reach the Ot3 parameter. The default for Ot3 is AL (alarms). Change the value to Ent (event) if it hasn't already been done. Press the MODE key to continue on to the Ot4 parameter. Do the same for this parameter also. Continue pressing the MODE key to exit the Setup menu.

If you return to the Operation menu, Ent1 and Ent2 are visible, and can be turned ON or OFF from here. Ent1 and Ent2 can also be viewed under the StPt (Set Point) and SoAh (Soak) parameters in the Program menu.

These event outputs are mechanical relays rated at 6 amps up to 240VAC.

Guaranteed Soak Deviation

The Series 942 Guaranteed Soak Deviation (gSd) feature insures that the actual temperature tracks a programmed profile within a window around set point. See the example on the next page. If the deviation is exceeded, the time clock stops and the lower display alternately flashes gSd and the current parameter until the process variable returns within the window. Programmed in degrees or units, gSd is located in the Setup menu. Entering a value of (0) disables the Guaranteed Soak Deviation function.

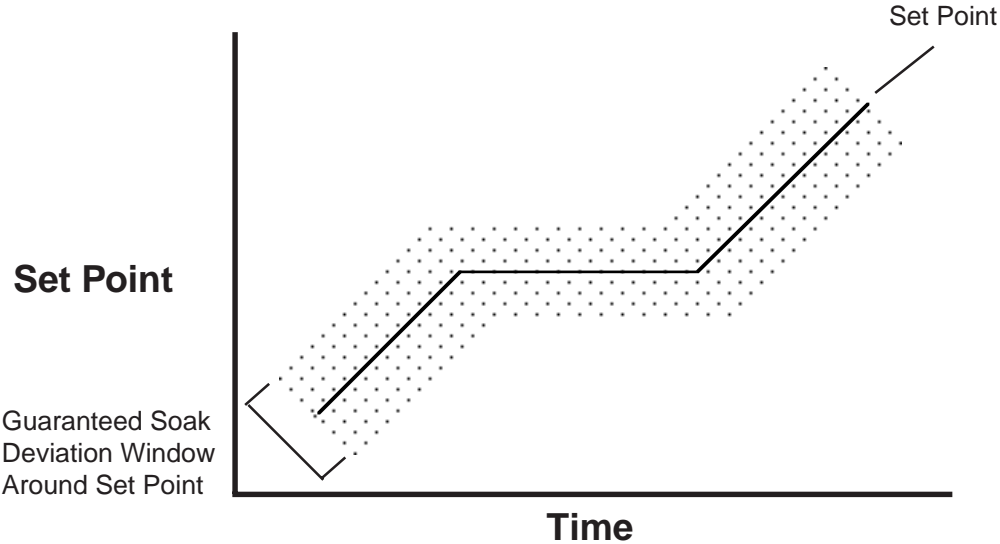

**Figure 37 -
Guaranteed Soak
Deviation Example**

Multiple Profiles

The Series 942 is a single profile control, but can be programmed for multiple profiles. To do this, enter your first profile; the next step you enter following the End step is the start of another profile. You can continue entering profiles until you run out of steps, remember there are a total of 24 steps.

Jumploop

The Series 942 can only jump backwards. A jump forces you to a step already performed. The Jump Step (JS) must be less than the current step. You cannot jumploop to the step that you are on.

	Step 2	StPt		
	Step 3	StPt		
	Step 4	StPt		
	Step 5	Jumploop	JS - 02	JC - 01
	Step 6	End		

Your Jump Count (JC) can be anything from 0 - 100. If you enter 0, this will be an infinite loop and never progresses to Step 6.

Programming a Ramping Profile

Our first step in programming is to make a short ramp and soak profile. Step 1 initializes the set point to a known starting point for the ramp, Step 2 is a short ramp, and Step 3 is a soak step, which holds the programmed set point constant for the programmed time. Step 4 is an end step signalling the end of the profile.

1. When the lower display reads set point, press MODE once and you see the Prog parameter. Select YES in the upper display. Press the MODE key once again.
2. The Series 942 asks you for a StEP. The upper display reads (1).
3. Press the MODE key and you are asked for a step type (StYP). The default is End. Use the UP/DOWN keys to select StPt (set point) then press MODE if it is not already there.
4. Use Table 4 to enter the corresponding parameters and values. The parameters appear from left to right on the table. Remember that the MODE key is used to progress through the menu, and the UP/DOWN keys are used to select parameters and values.

Table 4 - Series 942 Ramp and Soak Profile

StEP	StYP (Step Type)	SP (Set Point)	HOuR	Min	SEC	Ent1	Ent2	End	rtn
1	StPt	75	0	0	1	OFF	OFF	--	nO
2	StPt	100	0	0	25	On	OFF	--	nO
3	SoAh	--	0	0	25	On	OFF	--	nO
4	End							OFF	YES

NOTE:

If auxiliary outputs are not present or Ot3 and Ot4 are selected as alarms, the Ent1 and Ent2 parameters will not appear in the program menu.

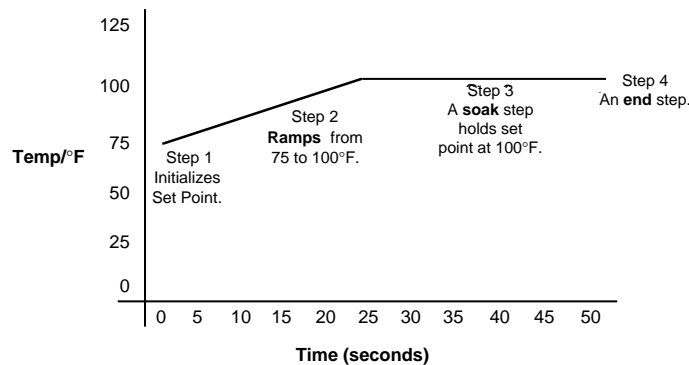

Running Your Profile

1. Start your profile by pressing the HOLD/RUN key. You can be at any point except the Setup menu.
2. The RUN LED begins flashing. The upper display shows the step to begin on, and the bottom display shows the StEP parameter.
3. Press the HOLD/RUN key again. If not pressed within approximately 1 minute, the RUN procedure will abort. The profile starts running.

Sample Program

The RUN LED is continually lit. The upper display shows the PROCESS value, and the lower display shows the current set point.

You may step through the Run menu parameters with the MODE key to see what the step type is and what the parameters are set at. At any time you may press the HOLD/RUN key to stop the profile. To resume running the profile where it was stopped, press the HOLD/RUN key once; the RUN LED begins flashing. Now, press the MODE key to advance to the rESU parameter; once again, press the HOLD/RUN key. After the profile has ended the Run LED is off and the lower display reads OFF. This means the End step was selected as OFF, disabling all outputs.

Editing Your Profile

Now let's try editing the profile by expanding it with another ramp and soak step, adding a jumploop and programming the End step to hold. We'll jump to Step 1 and repeat Steps 1 through 6 two more times. This is accomplished by programming a Jump Step (JS) = 1 and Jump Count (JC) = 2. This means that once the 942 goes through the profile and reaches Step 6, it jumps back to Step 1 and repeats the profile two more times (Steps 1 - 5). It then continues to Step 7 and holds the set point and event status of the last step of the profile before the end step was encountered.

By this time you should understand the basic concept of the Series 942 and be able to get around on your own. Remember that the MODE key takes you through the menus and the UP/DOWN keys select parameters and values.

1. Return to the PROGRAM menu by selecting YES when Prog appears.
2. Press the MODE key and select (4) when StEP appears. We are going to change this step type from an End step to a Set Point step. This is our second ramp. Use Table 5 to enter values into the corresponding parameters.
3. Once you have edited your profile, run it again and watch its progress.

Table 5 - Editing Your Profile, Steps 4 - 7.

StEP	StYP (Step Type)	SP (Set Point)	HOUr	Min	SEC	Ent1	Ent2	JS	JC	End	rtn
4	StPt	125	0	0	25	OFF	On	--	--	--	nO
5	StPt	125	0	0	25	On	OFF	--	--	--	nO
6	JL	--	--	--	--	--	--	1	2	--	nO
7	End	--	--	--	--	--	--	--	--	HOLd	YES

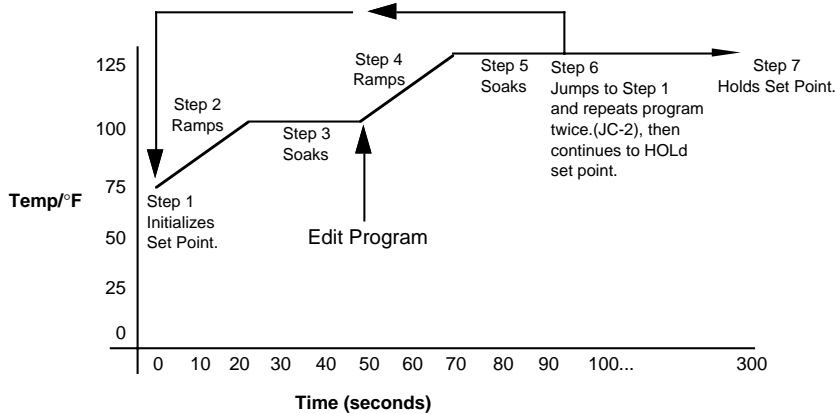

NOTE:
If auxiliary outputs are not present or Ot3 and Ot4 are selected as alarms, the Ent1 and Ent2 parameters will not appear in the Program menu.

Chapter 6

How to Tune and Operate

Tuning - Automatic

Auto-tuning: The Series 942 can automatically tune the PID parameters to fit the characteristics of your particular thermal system.

The auto-tuning procedure operates on a thermal response value — slow, medium, or fast. Use the slow thermal response when your process does not need to reach set point too rapidly, or if it usually does not exceed set point. A fast thermal response produces a rapid temperature change over a short period of time.

Once the auto-tune sequence has begun, the heat proportional band is set to 0 and the control goes into an ON/OFF mode of control at 90% of the established set point. The displayed set point remains unchanged.

The cool output remains off for the duration of tuning. Once the control finishes "learning" the system, it returns to a standard PID control with the heat PID values automatically set as a result of auto-tuning. Tuning is complete within 80 minutes. Any change of set point, while in auto-tune, re-initiates the auto-tune procedure.

To start auto-tuning:

1. **Press the MODE key** until the **AUt** parameter appears in the data display. The AUt parameter will not appear under the Operation menu if the set point value is OFF.
2. **Select a thermal response value**, 1 = slow, 2 = medium, and 3 = fast, using the UP/DOWN keys. A thermal response value of 2 satisfactorily tunes most thermal systems.
3. **Press the MODE key.** While the control is in the tuning mode, the lower display alternately displays the normal information and the **AUt** parameter. The time between alternations is 1 second.
4. **When tuning is complete**, the displays return to their previous state and **AUt** reverts to 0. The 942 installed the appropriate PID tuning parameters and saved them in the non-volatile memory.

To abort auto-tuning, reset the **AUt** parameter to 0, or cycle power off and on. In all cases, aborting auto-tune restores all original values.

Tuning - Manual

For optimum control performance, tune the Series 942 to the thermal system. The tuning settings here are for a broad spectrum of applications; your system may have somewhat different requirements. **NOTE: This is a slow procedure, taking from minutes to hours to obtain optimum value.**

- 1. Apply power to the Series 942** and enter a set point. Begin with these Operation Parameters: **Pb1** = 1, **rE1/It1** = 0.00, **Ct1** = 5, **rA1/dE1** = 0.00, **CAL** = 0, **AUt** = 0.
- 2. Proportional Band Adjustment (Output 1):** Gradually increase **Pb1** until the Upper display temperature stabilizes to a constant value. The process temperature will not be right on set point because the initial reset value is 0.00 repeats per minute. (When **Pb1** = 0; **rE1** and **rA1** are inoperative, and the 942 functions as a simple ON/OFF control.) The **HYSX** parameter determines the switching differential value.
- 3. Reset/Integral Adjustment:** Gradually increase **rE1/It1** until the upper display temperature begins to oscillate or "hunt." Then slowly decrease **rE1/It1** until the Upper display stabilizes again near set point.
- 4. Cycle Time Adjustment:** Set **Ct1** as required. Faster cycle times sometimes achieve the best system control. However, if a mechanical contactor or solenoid is switching power to the load, a longer cycle time may be desirable to minimize wear on the mechanical components. Experiment until the cycle time is consistent with the quality of control you want.
- 5. Rate/Derivative Adjustment:** Increase **rA1/dE1** to 1.00 minute. Then raise set point by 20° to 30°F, or 11° to 17°C. Observe the system's approach to set point. If the load temperature overshoots set point, increase **rA1/dE1** to 2.00 minutes.

Then raise set point by 20 to 30°F, or 11 to 17°C and watch the approach to the new set point. If you increase **rA1/dE1** too much, approach to the set point will be very sluggish. Repeat as necessary until the system rises to the new set point without overshooting or approaching the set point too slowly.

- 6. Calibration Offset Adjustment:** You may want your system to control to a temperature other than the value coming from the input sensor, such as when the sensor cannot directly measure the process. If so, measure the difference between that temperature (perhaps at another point in the system) and the process value showing in the Upper display. Then enter the **CAL** offset value you want. Calibration offset adds or subtracts degrees from the value of the input signal.

NOTE:
The cycle time (**Ct1**) parameter will not appear if Output 1 (**Ot1**) is a process output.

NOTE:
An **X** applies to either Hysteresis 1 or 2.

Changing the Position of an Auxiliary Jumper

Whenever you change the position of a jumper, follow this procedure:

1. Remove power from the Series 942. Turn the front panel screw 90° counter-clockwise.
2. Grip the front panel bezel and pull it straight out from the control case. The control chassis will come out of the case as you pull the bezel.
3. Set the jumper to the position you want. See Figure 38 for jumper location.
4. Return the control chassis to the case. Be sure you have it oriented correctly. It will not fit in upside down, but check just the same. Press firmly, but gently, to seat the chassis.

**Figure 38 -
Auxiliary Jumper
Location.**

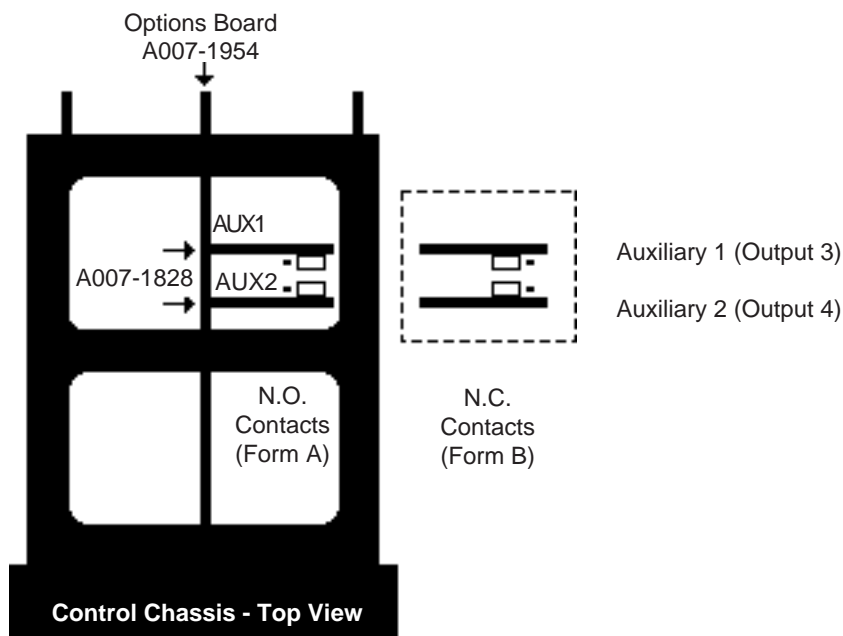

NOTE:
Depending on the
unit you order, your
control may have 0,
1, or 2 auxiliary
jumpers.

The auxiliary output de-energizes upon an alarm or power interruption to the 942's power supply. When you select **N.O. Contacts**, the contact is open when an alarm occurs. When selecting **N.C. Contacts**, the contact closes when an alarm occurs. When an event is ON the N.O. contacts close and the N.C. contacts open. If the L3 or L4 LED on the front panel are lit, this indicates an energized event or alarm condition for Output 3 or 4.

Using Alarms

The Series 942 has two alarm types, Process or Deviation. A **Process alarm** sets an absolute temperature. When the process exceeds that absolute temperature limit an alarm occurs. The Process alarm set points may be independently set high and low.

A **Deviation alarm** alerts the operator when the process strays too far from set point. The operator can enter independent high and low alarm settings. The reference for the deviation alarm is the set point. Any change in set point causes a corresponding shift in the deviation alarm. **Example:** If the set point is 100°F, and a deviation alarm is set at +7°F as the high limit, and -5°F as the low limit, the high alarm trips at 107°F, and the low alarm at 95°F. If you change the set point to 130°F, the alarms follow the set point and trip at 137°F and 125°F.

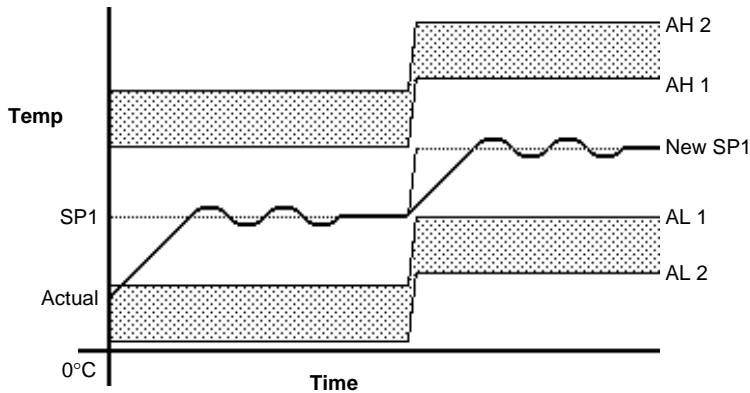

Figure 39 - Deviation Alarm Example

NOTE:
For Deviation alarms: When the End step in the Program menu is OFF or OFFA, the deviation alarms are active (relay energized).

For Process alarms: When the End step is OFF, process alarms are disabled in a de-energized position. When OFFA is selected, the process alarm works normally.

Both Process and Deviation alarms can be latching or non-latching. When the alarm condition is removed a **non-latching alarm automatically** clears the alarm output. The operator must **manually clear a latching alarm** before the alarm disappears. The alarm condition must also be removed before the alarm can be cleared.

Flashing "LO" or "HI" in the lower display indicates an alarm. The Lower display alternately shows information from the current parameter and the "LO" or "HI" alarm message at one second intervals. The alarm output is de-energized and the L3 or L4 LED is lit.

To clear an alarm...

- **First correct the alarm condition, then...**
 - **If the alarm is latching...**
Clear it manually; press the HOLD/RUN key once as soon as the process temperature is inside the alarm limit according to the HYSX parameter.
 - **If the alarm is non-latching...**
The alarm will clear itself automatically as soon as the process temperature is inside the alarm limit according to the HYSX parameter.

NOTE:
An **X** applies to either Hysteresis 3, or 4.

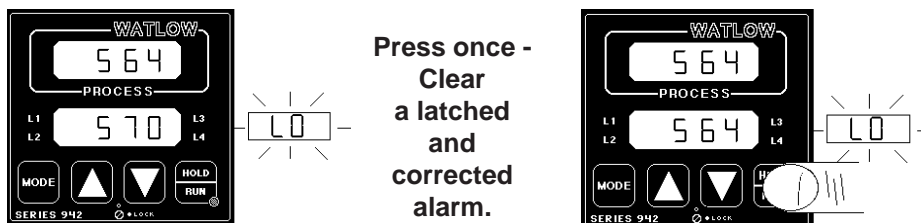

Figure 40 - Alarm Display Examples

Alarm Silencing for auxiliary output 3 is available with the deviation alarm. If it is a non-latching alarm, this overrides the normal alarm output functions only during initial power up. If latching, press the HOLD/RUN key once to override the alarm output function. With alarm silencing, the alarm message and alarm LED's show the alarm condition but the output remains in a non-alarm state until the process value is within the safe region of the deviation band. Any future deviation outside this safe band triggers an alarm.

WARNING:
An alarm display will be masked by an error condition or when the control is in the Calibration or Setup Menus.

Error Code Messages



Four dashes, "- - - -", in the upper display indicate a Series 942 error.

- The error code is visible in the lower display.

Figure 41 -
Error Code Display
Example

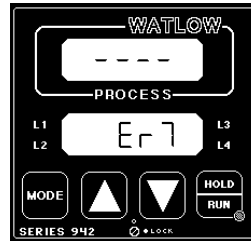

WARNING:

Electrical noise or a noise event, vibration or excess environmental moisture or temperature may cause Series 942 errors to occur. If the cause of an error is not otherwise apparent, check for these.

- **Error code definitions and actions...**

Er 1 - Sensor overrange error

The sensor input generated a value that was higher than that allowed for the range of the sensor, or the A/D circuitry malfunctioned. Enter a valid input. The A/D value is above the range limits, but within the A/D conversion limits. Make sure the **In** parameter matches your sensor.

Er 2 - Sensor underrange error

The sensor input generated a value that was lower than that allowed for the range of the sensor, or the A/D circuitry malfunctioned. Enter a valid input. The A/D value is below the range limits, but within the A/D conversion limits. Make sure the **In** parameter matches your sensor.

Er 3 - Ambient error

Check the specification for the ambient temperature range.

Er 4 - Configuration error

The unit's microprocessor is faulty; call the factory.

Er 5 - Non volatile checksum error

The nonvolatile memory checksum discovered a checksum error. Unless a momentary power interruption occurred while the unit was storing data, the nonvolatile memory is bad. Call the factory.

Er 6 - A/D underflow error

The A/D circuit is underrange. An open or reversed polarity sensor is the most likely cause. Check the sensor; if the connection is good, and the sensor functions properly, call the factory. The A/D underrange voltage is too low to convert an A/D signal. Make sure the **In** parameter matches your sensor.

Er 7 - A/D overflow error

The A/D circuit is overrange. An open or reversed polarity sensor is the most likely cause. Check the sensor; if the connection is good, and the sensor functions properly, call the factory. The A/D underrange voltage is too high to convert an A/D signal. Make sure the **In** parameter matches your sensor.

Error Code Actions

- **Error codes Er 1, Er 2, Er 3, Er 6, and Er 7 will result in these conditions:**
 - Control outputs turn OFF.
 - The auxiliary output (if present and programmed as an alarm) will be in the alarm state (LED lit). If programmed as an event, the output turns OFF.
 - The Upper display will read "- - - -".
 - The Lower display indicates the error code.
 - The HOLD/RUN and MODE keys are inactive. The UP/DOWN keys may be used together to enter the Setup Menu.
- **To clear a corrected error...**
 - Cycle power to the control, or MODE through the SETUP menu until you return to the set point.
 - If an error occurs while in the RUN mode, the program cannot be resumed. Set point defaults to the previous value.
- **Error codes Er 4 and Er 5 will result in these conditions:**
 - Control outputs turn OFF.
 - The auxiliary outputs, if present, are in their alarm state (de-energized with the LED lit).
 - The Upper display indicates "- - - -".
 - The Lower display indicates the error code.
 - All Keys are inactive.
 - All Setup Menu parameters return to default values.
 - The above conditions will occur regardless of the value of LOC, or the presence of the Setup or Calibration Menus.
- **To clear a corrected error...**
 - Cycle power to the control.

Control Mode

- 24 step ramping control or programmer.
- Simple, non-ramping set point.
- Single input, dual outputs.
- Optional dual auxiliary outputs, selectable as alarms or time based events.
- Optional retransmit of set point or process variable.
- RS-422A, RS-423A, or EIA-485 data communications available.
- Control outputs: User selectable as: Heat, Heat/Cool, Cool, Cool/Heat
 - Outputs independent, related via dead band for Heat/Cool.
 - ON/OFF: Selectable per Outputs 1 and 2.
 - Proportional band: 0 to 999°F/0 to 555°C/0 to 999 Units or % of span
Reset: 0.00 to 9.99 repeats per minute.
Integral: 0 and 00.1 to 99.9 minutes per repeat.
Rate/Derivative: 0.00 to 9.99 minutes.
Cycle time: 1 to 60 seconds.
 - Dead band: $\pm 99^\circ\text{F}$, $\pm 55^\circ\text{C}$ or ± 99 Units
($\pm 9.9^\circ\text{F}$, $\pm 5.5^\circ\text{C}$ or ± 9.9 units for rtd.1 and process units)

NOTE:

An **X** applies to either Hysteresis 1, 2, 3, or 4.

Operator Interface

- Membrane front panel.
- Dual, four digit 0.56" (14 mm) LED displays.
- MODE, HOLD/RUN, UP, and DOWN keys.

Input

- Thermocouple, RTD, and electrical process input.
- Automatic cold junction compensation for thermocouple.
- RTD input 2 or 3 wire, platinum, 100 ohm @ 0°C, software selectable: JIS curve #3916 (0.003916 $\Omega/\Omega/^\circ\text{C}$) or DIN curve #3850 (0.003850 $\Omega/\Omega/^\circ\text{C}$).
- Sensor break protection de-energizes control outputs to protect system.
- Grounded or ungrounded sensors.
- °F, °C, or process variable units are user selectable.
- J t/c: 32 to 1382°F or 0 to 750°C
- K t/c: -328 to 2282°F or -200 to 1250°C
- T t/c: -328 to 662°F or -200 to 350°C
- N t/c: 32 to 2282°F or 0 to 1250°C
- C t/c: 797 to 4200°F or 425 to 2315 °C
- PT 2 (Platinel 2) 32 to 2543°F or 0 to 1395°C
- R t/c: 32 to 2642°F or 0 to 1450°C
- S t/c: 32 to 2642°F or 0 to 1450°C
- *B t/c: *32 to 3092°F or 0 to 1700°C
- 1° RTD: -328 to 1112°F or -200 to 600°C
- 0.1° RTD: -99.9 to 392.0°F or -99.9 to 200.0°C
- 0-5VDC: -500 to 3500 Units
- 4-20mA: -500 to 3500 Units

NOTE:

* B t/c: Useable range is suggested to be 1598 to 3092°F or 870 to 1700°C. Range is at 32° to allow using at low temperatures without range low sensor errors.

Primary Output (Heating or Cooling)

- Solid state relay, Form A 0.5A @ 24VAC min., 264VAC maximum, opto-isolated, zero cross switching. Off state impedance is 20K Ω minimum for 942A-XBXX-X0000 units, and infinite impedance for 942A-XKXX-X000 units.
- Electromechanical relay, Form C, 6A @ 120/240VAC, 6A @ 28VDC, 1/8 hp. @ 120VAC, 125VA @ 120VAC. Off state impedance is 20K Ω min.
- Switched DC Open collector, 500 Ω minimum load resistance, 1K Ω load, 9mA minimum, 22mA maximum, non-isolated.
- 0-20mA or 4-20mA reverse or direct into a 600 Ω maximum load impedance, non-isolated.
- 0-10VDC or 0-5VDC reverse or direct into a 1K Ω minimum load impedance, non-isolated.

Secondary Output (Heat, Cool or None)

- Solid state relay, Form A 0.5A @ 24VAC min., 264VAC maximum, opto-isolated, zero cross switching. Off state impedance is 20K Ω minimum for 942A-XBXX-X0000 units, and infinite impedance for 942A-XKXX-X000 units.
- Electromechanical relay, Form A, 6A @ 120/240VAC, 6A @ 28VDC, 1/8 hp. @ 120VAC, 125VA @ 120VAC. Off state impedance is 20K Ω min.
- Switched DC, Open collector, 500 Ω minimum load resistance, 1K Ω load, 9mA minimum, 22mA maximum, non-isolated.

Auxiliary Outputs

- Electromechanical relay, Form A (N.O.) or B (N.C.), 6A @ 28VDC, 1/8 hp. @ 120VAC, 125VA @ 120VAC. Off state impedance is 20K Ω minimum.
- Latching or non-latching.
- Process or deviation.
- Separate high and low values.
- Alarm silencing (inhibit) on power up for Alarm 1.

Retransmit Output

- 4-20mA into a 600 Ω maximum load, non-isolated. Retransmit of process or set point. User selectable range.
- 0-5VDC into a 10K Ω minimum load, non-isolated. Retransmit of process or set point. User selectable range.

Accuracy

- Calibration Accuracy and Sensor Conformity: $\pm 0.1\%$ of span, ± 1 LSD, 77°F \pm 5°F (25°C \pm 3°C) ambient & rated line voltage $\pm 10\%$.
- Accuracy Span: 1000°F or 540°C minimum.
- Temperature Stability: 0.1°F/°F (0.1°C/°C) change in ambient.
- Voltage Stability: $\pm 0.01\%$ of span / % of rated line voltage.

Communications

- Serial data communications.
- RS-422A or RS-423A (RS-232C compatible) or EIA-485, user selectable.
- ANSI X3.28 protocol, or XON/XOFF protocol.
- Isolated.
- Data logging.
- #6 compression type screw terminals.

Agency Approvals

- UL and CSA pending.

Terminals

- #6 compression type screw terminals.

Power

- 120/240VAC +10%, -15%, 50/60Hz, $\pm 5\%$.
- 16VA maximum.
- Data retention upon power failure via nonvolatile memory.

Operating Environment

- 32 to 149°F/0 to 65°C.
- 0 to 90% RH, non-condensing.

Dimensions

- | | | |
|-----------------------|-------------|--------|
| • Height: | 3.8 in | 97 mm |
| • Width: | 3.8 in | 97 mm |
| • Overall depth: | 7.0 in | 178 mm |
| • Behind panel depth: | 6.0 in | 153 mm |
| • Weight: | 2.5 lb max. | 0.4 kg |

Series 942 Model Number Information

The Series 942 Model Number, listed on your unit sticker, is defined below.

9 4 2 A - - - - - 0 0 0

Control Series

942 = 1/4 DIN, single input, dual output, dual auxiliary outputs, dual digital displays.

Inputs Type

- 1 = Type J, K, T, N, C, PT 2 thermocouple
- 2 = Type J, K, T, N, C, PT 2 thermocouple, RTD 1°, 4 - 20mA, 0-5VDC
- 3 = Type J, K, T, N, C, PT 2 thermocouple, RTD 0.1°, 4 - 20mA, 0-5VDC
- 4 = Type R, S, B thermocouple

#1 Output Type

- B = Solid State Relay, Form A, 0.5A
- C = Switched DC, Open Collector, non-isolated
- D = Mechanical Relay, Form C, 6A
- E = Process 0 - 10VDC, non-isolated
- F = Process 4 - 20mA, non-isolated
- G = Process 0 - 20mA, non-isolated
- H = Process 0 - 5VDC, non-isolated
- K = Solid State Relay without contact suppression Form A, 0.5A

#2 Output Type

- A = None
- B = Solid State Relay, Form A, 0.5A
- C = Switched DC, Open Collector, non-isolated
- D = Mechanical Relay, Form C, 6A
- K = Solid State Relay without contact suppression Form A, 0.5A

Auxiliary Outputs

- 0 = None
- 1 = Single, Mechanical Relay, 6A, Form A or B
- 2 = Dual, Mechanical Relay, 6A, Form A or B
- 3 = Single, Mechanical Relay, 6A/0 - 5VDC retransmit
- 4 = Single, Mechanical Relay, 6A/4 - 20mA retransmit
- 5 = No auxiliary output/0 - 5VDC retransmit
- 6 = No auxiliary output/4 - 20mA retransmit

Communications

- A = None
- B = Isolated RS-423/RS-422
- D = Isolated EIA-485

Appendix 2

Noise and Installation Guidelines

Installation Guidelines For Preventing Noise

For improved electrical noise immunity, install the Series 942 as far away as possible from motors, relays, and other similar electrical noise generators.

Do not run low power (sensor input) lines in the same bundle as AC power lines. Grouping these lines in the same bundle can create electrical noise interference which may result in error codes in the Series 942.

The Culprit

Most noise problems stem from wiring practices. They're the major means of coupling noise from its sources to the control circuit. The following information will tell you how to eliminate or decrease noise.

An Information Resource

For wiring guidelines, refer to the IEEE Standard No. 518-1982, available from IEEE, Inc. 345 East 47th Street, New York, NY 10017.

Noise Sources

- Switches and relay contacts operating inductive loads such as motors, coils, solenoids, and relays, etc.
- Thyristors or other semiconductor devices which are not zero crossover-fired (randomly-fired or phase angle-fired devices).
- All welding machinery.
- Heavy current carrying conductors.
- Fluorescent and neon lights.

How To Decrease Noise Sensitivity

- Physical separation and wire routing must be given careful consideration in planning the layout of the system. For example, A.C. power supply lines should be bundled together and physically kept separate from input signal lines (sensor lines). A 12" (305 mm) minimum separation is usually effective. Keep all switched output signal lines (high power level) separate from input signal lines (sensor lines). Cross other wiring at 90° angles whenever crossing lines is unavoidable.

- Another important practice is to look at the system layout; identify and locate electrical noise sources such as solenoids, relay contacts, motors, etc. Route the wire bundles and cables as far away as possible from these noise sources. Don't mount relays or switching devices close to a microprocessor control. Don't have phase angle-fired devices in the same electrical enclosure or on the same power line with the control.
- Shielded cables should be used for all low power signal lines to protect from magnetic and electrostatic coupling of noise. Some simple pointers are:
 - ◊ Whenever possible, run low level signal lines unbroken from signal source to the control circuit.
 - ◊ Connect the shield to the control circuit common at the control end only. Never leave the shield unconnected at both ends. Never connect both shield ends to a common or ground.
 - ◊ Maintain shield continuity at daisy chain connection points by reconnecting the broken shield.
 - ◊ Assume no electrostatic shielding when using the shield as a signal return. If you must, use triaxed cable (electrostatically shielded coaxial cable).
- Twisted pair wire should be used any time control circuit signals must travel over two feet, or when they are bundled in parallel with other wires.
- The size or gauge of wire should be selected by calculating the maximum circuit current and choosing the gauge meeting that requirement. Using greatly larger wire sizes than required generally will increase the likelihood of electrostatic (capacitance) coupling of noise.
- Ground loops must be eliminated in the entire control system. There are obvious loops which can be spotted by studying the "as-built" wiring diagram. There are also the not-so-obvious ground loops that result from connecting internal circuit commons in the manufacturer's equipment. An example is a control circuit designed to work with a grounded sensor input.
- Do not daisy chain A.C. power (or return) lines, or output signal (or return) lines to multiple control circuits. Use a direct line from the power source to each input requiring A.C. power. Avoid paralleling L1 (power lead) and L2 (return lead) to load power solenoids, contactors, and control circuits. If an application uses L1 (power lead) to switch a load, L2 (return lead) has the same switched signal and could couple unwanted noise into a control circuit.
- Grounding the chassis of each piece of equipment in the system is very important. Here is a simple practice that works best. 1) Connect each individual equipment to the over-all chassis immediately adjacent to that piece. 2) Tie all major chassis ground terminals together with one lead (usually green wire) tied to ground at one point. Don't connect ground to the control case if the control is in a grounded enclosure (preventing ground loops).
- Do not confuse chassis grounds (safety ground) with control circuit commons or with A.C. supply L2 (return or neutral line). Each return system wiring must be separate. Absolutely never use chassis ground (safety) as a conductor to return circuit current.

How To Eliminate Noise

- Use "snubbers" ("QUENCHARC™") to filter out noise generated by devices such as relays, relay contacts, solenoids, motors, etc. A snubber is a simple filter device using a 0.1 μ f, 600 volt, non-polarized capacitor in series with a 100 ohm, 1/2 watt resistor. The device can be used on A.C. or D.C. circuits to effectively dampen noise at its source.
- The general purpose Watlow snubber, described above, is 0804-0147-0000. For other "QUENCHARC" sizes contact:

PAKTRON
 P.O. Box 5439
 Lynchburg, VA 24502
 Phone: 804/239-6941

- A Metal Oxide Varistor (MOV) can be used to limit voltage "spikes" that occur on the A.C. supply lines as a result of lightning strikes, switching large motors, etc. The MOV is available in several varieties and for 115 or 230 volt lines. The device dissipates the voltage "spikes" to ground and in doing so repeatedly, deteriorates its ability to function. MOVs have a limited life. Watlow stocks several MOVs. See Table 7.
- "Islatrols" and other similar power line filters are designed to carry the power for the control circuit and "buffer" the control circuit from A.C. line noise. Devices like the Islatrol use media (electromagnetic filtering) other than electric circuits to filter out electrical noise. Take care in matching the power capabilities of the filter with power demands of the circuit. Keep line filters as close to the control as possible to minimize the area for interference pick up.
- Islatrols are available from:

Control Concepts Corporation	
328 Water Street	
P.O. Box 1380	
Binghamton, NY 13902-1380	
Phone: 607/724-2484	

I - 101 (1A, 120VAC)	I - 202 (2.5A, 208/240VAC)
I - 105 (5A, 120VAC)	I - 207 (7.5A, 208/240VAC)
I - 115 (15A, 120VAC)	
- The ultimate protection is an "uninterruptable" power supply. This "senses" the A.C. power line; when the line fluctuates, a battery powered 60Hz inverted circuit takes over, supplying power within one-half to one cycle of the A.C. line; very expensive.

How to Check for Ground Loops

To check for ground loops, disconnect the ground wire at the ground termination. Measure the resistance from the wire to the point where it was connected. The ohmmeter should read a high ohm value. If you have a low ohm value across this gap, there is at least one ground loop present in your system.

Or check for continuity; your reading should be "open." If you do find continuity, you must now begin looking for the ground loops. Begin disconnecting ground in the system one at a time, checking for continuity after each disconnection. When continuity reads "open" you have eliminated the ground loop(s). Also, as you reconnect grounds, keep making the continuity test. It is possible to reconnect a ground loop.

Noise Suppression Devices Available From Watlow

Watlow Controls stocks a few key noise suppression parts. You may order these by calling your local Watlow distributor.

**Table 6 -
Noise Suppression
Device Ratings**

Item	Electrical Ratings	Part Number
Differential Mode Line Filter	Refer to the Islatrol listing above.	
Metal Oxide Varistor	150V, 80 Joule	0802-0273-0000
MOV130V, 38 Joule	0802-0304-0000	
MOV275V, 75 Joule	0802-0266-0000	
MOV275V, 140 Joule	0802-0405-0000	

Line Filtering Configurations For Controls

These three diagrams show you filter configurations for removing input power noise. Choose the one best suited for your system. For very dirty or critical applications - use a microcomputer-regulated power supply or Uninterruptable Power Supply (U.P.S.). Don't fasten common mode line filters or filters with metal cases to metal that is at ground potential. This prevents ground loops and maintain filter effectiveness.

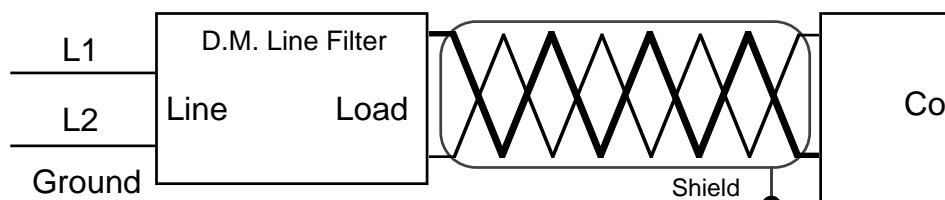

**Figure 42 -
Differential Mode
Filter Wiring**

NOTE:
Keep filters 12" (305 mm) or less from the control. Minimize the line distance where noise can be reintroduced to the control.

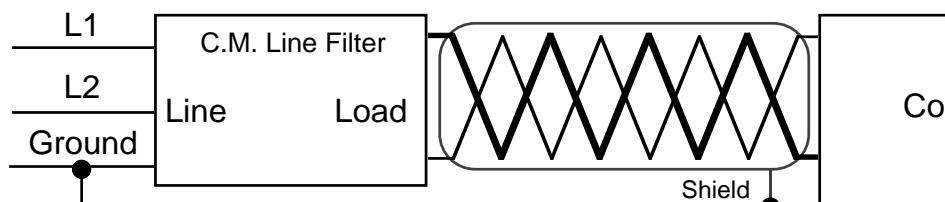

**Figure 43 -
Common Mode Filter
Wiring**

NOTE:
To prevent ground loops do not fasten common mode line filters or filters with metal that is at ground potential. Doing so will reduce filter effectiveness.

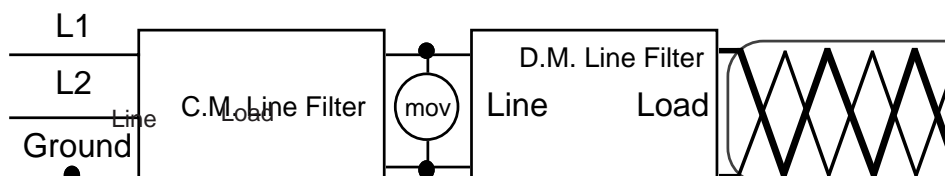

**Figure 44 -
Combination
Differential/Common
Mode Filter Wiring**

Appendix 3

Before attempting to calibrate, make sure you have the proper equipment called for in each procedure.

Entering the Calibration Menu

In the Calibration Menu, various input signals must be supplied in order for the control to go through its auto calibration. The calibration menu can only be entered from the LOC parameter in the Setup menu. Press the UP/DOWN keys simultaneously for 3 seconds (± 1 second). The CAL parameter appears in the lower display with "no" in the upper display.

Figure 45 -
Entering the
Calibration Menu.

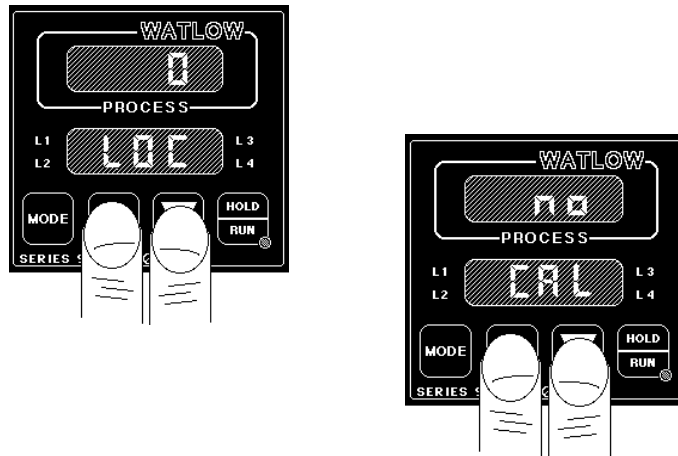

NOTE:
Calibration values are not retained unless you are in the RUN mode. Do not enter the RUN mode until you are at the correct input parameters.

NOTE:
While in the Calibration Menu, all outputs are OFF, except the process output.



WARNING:
Improper calibration will affect the accuracy of your control. A factory restore (rst) feature is provided at the end of the Calibration menu.

Any inadvertent change in the displayed data, when pressing the UP/DOWN keys, is ignored. Calibration values are not retained unless you are in the RUN mode. Press the UP/DOWN keys to change the upper display to "YES." Press the MODE key to enter the calibration sequence.

Upon entering the calibration menu, the top display window indicates CAL. The upper display continues to indicate CAL (with the exception of calibration of the process outputs) while the operator walks through the entire calibration parameter list. While calibrating a process output, the upper display contains a numeric value to be slewed up or down until the output value is correct. The control uses the lower display to prompt the user as to what the input should be. **The rSt parameter restores the factory calibration values to the Series 942.** If you calibrate your control incorrectly, you have the option to default to the original values. Once you leave the CAL menu, the values are entered.

The dFL parameter allows you to select either U.S. parameters which include displaying the proportional band in degrees or units, rate, reset, and °F. Or you can select SI (System International); those parameters displayed are proportional band in % of span, integral, derivative, and °C.

Once the information has been properly established and maintained for 5 to 10 seconds, the MODE key can be used to display the next parameter. After the final input is established, press the MODE key to return the unit to the configuration menu at the top of the parameter list.

Calibration Menu

CAL ()	YES to calibrate, No skips to display test.
tCL ()	Input 0.00mV for low thermocouple input.
tCH ()	Input 50.00mV (or 16.035 for r, S or b units) for high thermocouple input.
tC ()	Connect a "J" T/C compensator, with inputs shorted. T/C units only.
rLO ()	Connect the JIS RTD low resistance per model number.
rHI ()	Connect the JIS RTD high resistance per model number.
0 U ()	Set the voltage source to 0.000 volts.
5 U ()	Set the voltage source to 5.000 volts.
4 A ()	Set the current source to 4.00mA.
20A ()	Set the current source to 20.00mA.
O1LO ()	Press the UP/DOWN keys until Output 1 reads process low.
O1HI ()	Press the UP/DOWN keys until Output 1 reads process high.
4tYP ()	Factory select for Output 4 type.
O4LO ()	Press the UP/DOWN keys until Output 4 reads process low.
O4HI ()	Press the UP/DOWN keys until Output 4 reads process high.
rst ()	Restores factory calibration values.
dISP ()	Factory use only.
dFL ()	Select US (prop. band in ° or units, rate, reset, °F) or SI (prop. band in % of span, integral, derivative, °C).
MEM ()	Factory use only.

Figure 46 - Calibration Menu

NOTE:
The Output 4 rELY parameter is for alarms or events, and the PrOC parameter is for retransmit output.

Thermocouple Field Calibration Procedure

Before attempting to calibrate, make sure you have the proper equipment called for in each procedure.

Equipment Required

- Type "J" or "R" reference compensator with reference junction at 32°F/0°C, or
Type "J" or "R" thermocouple calibrator set at 32°F/0°C.
- Precision millivolt source, 0 - 50mV minimum range, 0.01mV resolution

NOTE:

Before calibration on an installed control, make sure all data and parameters are documented. See the Setup and Operation Tables, and the Master Step Chart, Pages 27, 30 and 35.

Setup And Calibration

1. Connect the AC line voltage L1, L2, and ground to the proper terminals on the 942. See Chapter 2.
2. Connect the millivolt source to Terminal #9 Negative and Terminal #7 Positive on the Series 942 terminal strip. Use regular 20 - 24 gauge wire.
3. Apply power to the unit and allow it to warm up for 15 minutes. **After warm-up** put the unit in the CAL menu. See Page 54.

IMPORTANT:

When the RUN LED is ON the unit is automatically calibrating. Your sequence is VERY important. Always move to the next parameter before changing the calibration equipment. When you have completed all of the thermocouple calibration parameters, press the HOLD/RUN key twice. Failure to do so will result in inaccurate calibration values.

NOTE:

Not all parameters will appear. They are dependent on your unit type. Use only the steps that apply to your unit.

4. Press the HOLD/RUN key twice to enter the RUN mode. The unit is calibrating when the RUN LED is ON. Make sure the unit is in the RUN mode **only** when you are in the correct parameters. See Page 55.
5. At the **tCL** parameter, enter 0.00mV from the millivolt source to the control. Allow at least 10 seconds to stabilize. Press the MODE key.
6. At the **"CH** parameter, enter 50.00mV for type "J" units or 16.035mV for type "R" units from the millivolt source to the Series 942. Allow at least 10 seconds to stabilize. Press the MODE key.
7. At the **tC** parameter, disconnect the millivolt source, and connect the reference compensator or T/C calibrator to Terminal #9 Negative, and Terminal #7 Positive on the Series 942 terminal strip. Allow 10 seconds for the control to stabilize. The unit will leave the CAL mode if 1 minute passes between key activations. Press the HOLD/RUN key twice to exit the RUN mode. To conclude the thermocouple calibration, advance the MODE key to the next parameter or exit the Calibration menu by pressing the HOLD/RUN key twice.

RTD Field Calibration Procedure

Before attempting any calibration procedure, make sure you have the proper equipment called for in each procedure.

Equipment Required

- 1KΩ precision decade resistance box with 0.01 ohms resolution.

Setup And Calibration

1. Connect the AC line voltage L1, L2, and ground to the proper terminals of the 942. See Chapter 2.
2. Connect the decade resistance box to Terminal #4, 5 and 6 on the terminal strip. Use regular 20 - 24 gauge wire of the same length and type.
3. Apply power to the unit and allow it to warm up for 15 minutes. **After warm-up** put the unit in the CAL menu. See Page 54. Press the MODE key until the **rLO** parameter is displayed.

IMPORTANT:

When the RUN LED is ON the unit is automatically calibrating. Your sequence is VERY important. Always move to the next parameter before changing the calibration equipment. When you have completed all of the RTD calibration parameters, press the HOLD/RUN key twice. Failure to do so will result in inaccurate calibration values.

4. Press the HOLD/RUN key twice to enter the RUN mode. The unit is calibrating when the RUN LED is ON. Make sure the unit is in the RUN mode **only** when you are in the correct parameters. See Page 55.
5. At the **rLO** parameter, set the decade resistance box to the correct low setting. See the table below. This parameter can be calibrated to JIS or DIN. Allow at least 10 seconds to stabilize. Press the MODE key.

	Calibration	Low	High
942A-2XX0-0000	1°	17.31	317.33
942A-3XX0-0000	0.1°	59.59	177.13

6. At the **rHI** parameter, set the decade resistance box to the correct high setting. Allow at least 10 seconds to stabilize. The unit will leave the CAL mode if 1 minute passes between key activations. Press the HOLD/RUN key twice to exit the RUN mode. To conclude the RTD calibration, advance the MODE key to the next parameter or exit the Calibration menu by pressing the HOLD/RUN key twice.

NOTE:

Before calibration on an installed control, make sure all data and parameters are documented. See the Setup and Operation Tables, and the Master Step Chart, Pages 27, 30 and 35.

NOTE:

Not all parameters will appear. They are dependent on your unit type. Use only the steps that apply to your unit.

Table 7 - RTD Settings.

0 - 5 Volt Input Field Calibration Procedure

Before attempting any calibration procedure, make sure you have the proper equipment called for in each procedure.

Equipment Required

- Precision voltage source 0-5 volt minimum range with 0.001 volt resolution.

Setup And Calibration

1. Connect the AC line voltage L1, L2, and ground to the proper terminals on the 942. See Chapter 2.
2. Connect the voltage/current source to Terminal #1 and #3 on the Series 942 terminal strip. Use regular 20 - 24 gauge wire.
3. Apply power to the unit and allow it to warm up for 15 minutes. **After warm-up** put the unit in the CAL menu. See Page 54. Press the MODE key until the **OU** parameter is displayed.

NOTE:

Before calibration on an installed control, make sure all data and parameters are documented. See the Setup and Operation Tables, and the Master Step Chart, Pages 27, 30 and 35.

IMPORTANT:

When the RUN LED is ON the unit is automatically calibrating. Your sequence is VERY important. Always move to the next parameter before changing the calibration equipment. When you have completed all of the 0 - 5 Volt input calibration parameters, press the HOLD/RUN key twice. Failure to do so will result in inaccurate calibration values.

4. Press the HOLD/RUN key twice to enter the RUN mode. The unit is calibrating when the RUN LED is ON. Make sure the unit is in the RUN mode **only** when you are in the correct parameters. See Page 55.
5. At the **OU** parameter, set the voltage/current source to 0.000volts. Allow at least 10 seconds to stabilize. Press the MODE key.
6. At the **5U** parameter, set the voltage/current source to 5.000 volts. Allow at least 10 seconds to stabilize. The unit will leave the CAL mode if 1 minute passes between key activations. Press the HOLD/RUN key twice to exit the RUN mode. To conclude the 0 - 5 Volt input calibration, advance the MODE key to the next parameter or exit the Calibration menu by pressing the HOLD/RUN key twice.

NOTE:

Not all parameters will appear. They are dependent on your unit type. Use only the steps that apply to your unit.

4-20mA Input Field Calibration Procedure

Before attempting any calibration procedure, make sure you have the proper equipment called for in each procedure.

Equipment Required

- Precision current source 0-20mA minimum range with 0.01 mA resolution.

Setup And Calibration

1. Connect the AC line voltage L1, L2, and ground to the proper terminals on the Series 942. Jumper for correct line voltage. See Chapter 2.
2. Connect the voltage/current source to Terminal #1 and #3. Jumper Terminal #2 to #3 on the Series 942 terminal strip. Use regular 20 - 24 gauge wire.
3. Apply power to the unit and allow it to warm up for 15 minutes. **After warm-up** put the unit in the CAL menu. See Page 54. Press the MODE key until the **4A** parameter is displayed.

IMPORTANT:

When the RUN LED is ON the unit is automatically calibrating. Your sequence is VERY important. Always move to the next parameter before changing the calibration equipment. When you have completed all of the 4 - 20mA input calibration parameters, press the HOLD/RUN key twice. Failure to do so will result in inaccurate calibration values.

4. Press the HOLD/RUN key twice to enter the RUN mode. The unit is calibrating when the RUN LED is ON. Make sure the unit is in the RUN mode **only** when you are in the correct parameters. See Page 55.
5. At the **4A** parameter, set the mA source to 4.00mA. Allow at least 10 seconds to stabilize. Press the MODE key.
6. At the **20A** parameter, set the voltage/current source to 20.00mA. Allow at least 10 seconds to stabilize. The unit will leave the CAL mode if 1 minute passes between key activations. Press the HOLD/RUN key twice to exit the RUN mode. To conclude the 4-20mA input calibration, advance the MODE key to the next parameter or exit the Calibration menu by pressing the HOLD/RUN key twice.

NOTE

Before calibration on an installed control, make sure all data and parameters are documented. See the Setup and Operation Tables, and the Master Step Chart, Pages 27, 30 and 35.

NOTE:

Not all parameters will appear. They are dependent on your unit type. Use only the steps that apply to your unit.

0-5 or 0-10 Volt Output Field Calibration Procedure

Before attempting any calibration procedure, make sure you have the proper equipment called for in each procedure.

Equipment Required

- 20K Ω , 1/4 watt, 10% resistor
- 4 1/2 digit Digital Multimeter.

Setup and Calibration

1. Connect the AC line voltage L1, L2, and ground to the proper terminals of the 942. See Chapter 2.
2. Connect the multimeter across the 20K Ω resistor to Terminal #17 (+) and #18 (-) for 0-5Volt units on the Series 942 terminal strip. Use Terminal #17 (+) and #16 (-) for 0-10Volt units. Use regular 20 - 24 gauge wire.
3. Apply power to the unit and allow it to warm up for 15 minutes. **After warm-up** put the unit in the CAL menu. See Page 54. Press the MODE key until the **O1LO** parameter is displayed.

NOTE

Before calibration on an installed control, make sure all data and parameters are documented. See the Setup and Operation Tables, and the Master Step Chart, Pages 27, 30 and 35.

IMPORTANT:

When the RUN LED is ON the unit is automatically calibrating. Your sequence is VERY important. Always move to the next parameter before changing the calibration equipment. When you have completed all of the 0 - 5 Volt output calibration parameters, press the HOLD/RUN key twice. Failure to do so will result in inaccurate calibration values.

4. Press the HOLD/RUN key twice to enter the RUN mode. The unit is calibrating when the RUN LED is ON. Make sure the unit is in the RUN mode **only** when you are in the correct parameters. See Page 55.
5. At the **O1LO** parameter, the multimeter should read approximately 0.000V. Allow at least 10 seconds to stabilize.
6. Use the UP/DOWN keys (reverse acting) to adjust the reading on the multimeter for $-0.2V \pm 0.1V$ on 0-5Volt units and $0.0V \pm 0.1V$ for 0-10Volt units. Press the MODE key.
7. At the **O1HI** parameter, the multimeter should read approximately 5.000V. Allow at least 10 seconds to stabilize. The unit will leave the CAL mode if 1 minute passes between key activations.
8. Use the UP/DOWN keys (reverse acting) to adjust the reading on the multimeter for $5.2V \pm 0.1V$ for 0-5Volt units and $5.0V \pm 0.1V$ for 0-10Volt units.
9. Press the HOLD/RUN key twice to exit the RUN mode. To conclude the output calibration, advance the MODE key to the next parameter or exit the Calibration menu by pressing the HOLD/RUN key twice.

0-20/4-20mA Output Field Calibration Procedure

Before attempting any calibration procedure, make sure you have the proper equipment called for in each procedure.

Equipment Required

- 470Ω, 1/2 watt 10% resistor.
- 4 1/2 digit Digital Multimeter.

Setup and Calibration

1. Connect the AC line voltage L1, L2, and ground to the proper terminals of the 942. See Chapter 2.
2. Connect the multimeter in series with the 470Ω resistor to Terminal #17 (+) and #18 (-) for 4-20mA units, on the Series 942 terminal strip. Use Terminal # 17 (+) and #16 (-) for 0-20mA units. Use regular 20 - 24 gauge wire.
3. Apply power to the unit and allow it to warm up for 15 minutes. **After warm-up** put the unit in the CAL menu. See Page 54. Press the MODE key until **O1LO** parameter is displayed.

NOTE

Before calibration on an installed control, make sure all data and parameters are documented. See the Setup and Operation Tables, and the Master Step Chart, Pages 27, 30 and 35.

IMPORTANT:

When the RUN LED is ON the unit is automatically calibrating. Your sequence is VERY important. Always move to the next parameter before changing the calibration equipment. When you have completed all of the 4-20mA output calibration parameters, press the HOLD/RUN key twice. Failure to do so will result in inaccurate calibration values.

4. Press the HOLD/RUN key twice to enter the RUN mode. The unit is calibrating when the RUN LED is ON. Make sure the unit is in the RUN mode **only** when you are in the correct parameters. See Page 55.
5. At the **O1LO** parameter, the multimeter should read approximately 0mA for 0-20mA units and 4mA for 4-20mA units. Allow at least 10 seconds to stabilize.
6. Use the UP/DOWN keys (reverse acting) to adjust the reading on the multimeter for $0.0\text{mA} \pm 0.10\text{mA}$ on 0-20mA units, and $3.85\text{mA} \pm 0.10\text{mA}$ on 4-20mA units. Press the MODE key.
7. At the **O1HI** parameter, the multimeter should read approximately 20mA. Allow at least 10 seconds to stabilize. The unit will leave the CAL mode if 1 minute passes between key activations.
8. Use the UP/DOWN keys (reverse acting) to adjust the reading on the multimeter for $20.0\text{mA} \pm 0.10\text{mA}$ on 0-20mA units and $20.15\text{mA} \pm 0.10\text{mA}$ on 4-20mA units.
9. Press the HOLD/RUN key twice to exit the RUN mode. To conclude the output calibration, advance the MODE key to the next parameter or exit the Calibration menu by pressing the HOLD/RUN key twice. Press the HOLD/RUN key twice to exit the RUN mode.

0 - 5 Volt Retransmit Field Calibration Procedure

Before attempting any calibration procedure, make sure you have the proper equipment called for in each procedure.

Equipment Required

- 20K Ω , 1/4 watt, 10% resistor.
- 4 1/2 digit Digital Multimeter.

Setup and Calibration

NOTE

Before calibration on an installed control, make sure all data and parameters are documented. See the Setup and Operation Tables, and the Master Step Chart, Pages 27, 30 and 35.

1. Connect the AC line voltage L1, L2, and ground to the proper terminals of the 942. See Chapter 2.
2. Connect the multimeter across the 20K Ω resistor to Terminal #25 Positive and #24 Negative on the Series 942 terminal strip. Use regular 20 - 24 gauge wire.
3. Apply power to the unit and allow it to warm up for 15 minutes. **After warm-up** put the unit in the CAL menu. See Page 54. Press the MODE key until the O4LO parameter is displayed.

IMPORTANT:

When the RUN LED is ON the unit is automatically calibrating. Your sequence is VERY important. Always move to the next parameter before changing the calibration equipment. When you have completed all of the 0 - 5 Volt retransmit calibration parameters, press the HOLD/RUN key twice. Failure to do so will result in inaccurate calibration values.

4. Press the HOLD/RUN key twice to enter the RUN mode. The unit is calibrating when the RUN LED is ON. Make sure the unit is in the RUN mode **only** when you are in the correct parameters. See Page 55.
5. At the **O4LO** parameter, the multimeter should read approximately 0V. Allow at least 10 seconds to stabilize.
6. Use the UP/DOWN keys (reverse acting) to adjust the reading on the multimeter for 0.0 volts. Press the MODE key.
7. At the **O4HI** parameter, the multimeter should read approximately 5V. Allow at least 10 seconds to stabilize. The unit will leave the CAL mode if 1 minute passes between key activations.
8. Use the UP/DOWN keys (reverse acting) to adjust the reading on the multimeter for 5.0 volts. Press the MODE key.
9. Press the HOLD/RUN key twice to exit the RUN mode. To conclude the 0 - 5 volt retransmit calibration, advance the MODE key to the next parameter or exit the Calibration menu by pressing the HOLD/RUN key twice.

4-20mA Retransmit Field Calibration Procedure

Before attempting any calibration procedure, make sure you have the proper equipment called for in each procedure.

Equipment Required

- 470Ω, 1/2 watt 10% resistor.
- 4 1/2 digit Digital Multimeter.

Setup and Calibration

1. Connect the AC line voltage L1, L2, and ground to the proper terminals of the 942. See Chapter 2.
2. Connect the multimeter in series with the 470Ω resistor to Terminal #25 Positive and #24 Negative on the Series 945 terminal strip. Use regular 20 - 24 gauge wire.
3. Apply power to the unit and allow it to warm up for 15 minutes. After **warm-up** put the unit in the CAL menu. See Page 54. Press the MODE key until the **O4LO** parameter is displayed.

NOTE

Before calibration on an installed control, make sure all data and parameters are documented. See the Setup and Operation Tables, and the Master Step Chart, Pages 27, 30 and 35.

IMPORTANT:

When the RUN LED is ON the unit is automatically calibrating. Your sequence is VERY important. Always move to the next parameter before changing the calibration equipment. When you have completed all of the 4 - 20mA retransmit calibration parameters, press the HOLD/RUN key twice. Failure to do so will result in inaccurate calibration values.

4. Press the HOLD/RUN key twice to enter the RUN mode. The unit is calibrating when the RUN LED is ON. Make sure the unit is in the RUN mode **only** when you are in the correct parameters. See Page 55.
5. At the **O4LO** parameter, the multimeter should read approximately 4mA. Allow at least 10 seconds to stabilize.
6. Use the UP/DOWN keys (reverse acting) to adjust the reading on the multimeter for 4.00mA. Press the MODE key.
7. At the **O4HI** parameter, the multimeter should read approximately 20mA. Allow at least 10 seconds to stabilize. The unit will leave the CAL mode if 1 minute passes between key activations.
8. Use the UP/DOWN keys (reverse acting) to adjust the reading on the multimeter for 20.00mA.
9. Press the HOLD/RUN key twice to exit the RUN mode. To conclude the 4 - 20mA retransmit calibration, advance the MODE key to the next parameter or exit the Calibration menu by pressing the HOLD/RUN key twice.